

TM 55-1425-429-14

TECHNICAL MANUAL

TRANSPORTABILITY GUIDANCE

STINGER WEAPON SYSTEM

HEADQUARTERS, DEPARTMENT OF THE ARMY

FEBRUARY 1981

TECHNICAL MANUAL }
NO. 55-1425-429-14 }

HEADQUARTERS
DEPARTMENT OF THE ARMY
WASHINGTON, DC 15 February 1981

TRANSPORTABILITY GUIDANCE
STINGER WEAPON SYSTEM

	Paragraph	Page
C H A P T E R 1 .	I N T R O D U C T I O N	
	Purpose and Scope	1-1 1-1
	Reporting of Recommendations and Comments	1-2 1-1
	Safety	1-3 1-1
	Definitions of Warnings, Cautions, and Notes	1-4 1-1
	2. TRANSPORTABILITY DATA	
S E C T I O N I .	G E N E R A L	
	Scope	2-1 2-1
	Descriptions	2-2 2-1
	General Transportation Policy	2-3 2-1
	II. CHARACTERISTICS AND RELATED DATA OF ITEMS	
	General	2-4 2-1
	Dimensions	2-5 2-2
	CONUS Freight Classification	2-6 2-2
C H A P T E R 3 .	S A F E T Y	
	General	3-1 3-1
	Specific Safety Requirements	3-2 3-1
C H A P T E R 4 .	A I R T R A N S P O R T A B I L I T Y G U I D A N C E	
S E C T I O N I .	G E N E R A L	
	Scope	4-1 4-1
	II. ARMY AIR TRANSPORT PROCEDURES	
	General	4-2 4-1
	External Transport	4-3 4-1
	Internal Transport	4-4 4-1
	III. TRANSPORT BY US AIR FORCE AIRCRAFT	
	General	4-5 4-2
C H A P T E R 5 .	H I G H W A Y T R A N S P O R T A B I L I T Y G U I D A N C E	
	Scope	5-1 5-1
	Safety	5-2 5-1
	General	5-3 5-1
C H A P T E R 6 .	M A R I N E A N D T E R M I N A L T R A N S P O R T A B I L I T Y G U I D A N C E	
	Scope	6-1 6-1
	General Rules for Stowing Crated, Unitized, Palletized, or Containerized Loads	6-2 6-1
	Safety	6-3 6-1
	Lifting and Loading	6-4 6-1
C H A P T E R 7	R A I L T R A N S P O R T A B I L I T Y G U I D A N C E	
S E C T I O N I .	G E N E R A L	
	Scope	7-1 7-1
	Maximum Utilization of Railcards	7-2 7-1
	II. TRANSPORT ON CONUS RAILWAYS	
	General	7-3 7-1
	Preparation of Items	7-4 7-1
	Loading	7-5 7-1
	III. TRANSPORT ON FOREIGN RAILWAYS	
	General	7-6 7-1
A P P E N D I X	R E F E R E N C E S	A-1

LIST OF ILLUSTRATIONS

<i>Figure Number</i>	<i>Title</i>	<i>Page</i>
2-1	STINGER weapon system equipment	2-3
2-2	STINGER weapon round in shipping and storage contained	2-3
2-3	STINGER missile round in shipping and storage container	2-3
2-4	Identification friend or foe (IFF) interrogator set, AN/PPX-3, in shipping and storage container	2-4
2-5	IFF programmer set, AN/GSX-1, in shipping and storage container	2-4
2-6	Carry rack for STINGER weapon rounds and missile rounds in M416, 1/4-ton trailer	2-4
2-7	STINGER weapon system support equipment	2-5
2-8	M151A2, 1/4-Ton truck	2-5
4-1	Assembly of nine STINGER weapon rounds of STINGER missile rounds in an A-22 aerial delivery, bag for external transport by helicopter	4-3
4-2	Unitized package of four STINGER weapon rounds or missile rounds in UH-1D helicopter	4-4
4-3	Unitized package of four STINGER weapon rounds or missile rounds in CH-47 helicopter	4-5
4-4	Unitized package of four STINGER weapon rounds or missile rounds, on 1/4-inch plywood, in UF-60A helicopter	4-5
4-5	Unitized package of four STINGER weapon rounds or missile rounds in CH-54 universal military pod	4-6
4-6	Preparation of the complete STINGER weapon round packed in wirebound and/or aluminum container for aerial delivery (sheets 1 through 10)	4-7
5-1	Loading and bracing (TL and LTL) of the complete STINGER round, in closed- or open-top van trailers, packed in wirebound and/or aluminum container (unitized and ununitized or palletized and unpalletized) (sheets 1 through 4)	5-2
6-1	Lifting diagram for crated, unitized, or palletized loads of STINGER weapon system items.	6-2
7-1	Loading and bracing (CL and LCL) of STINGER weapon system complete round in boxcars, pricked in wirebound and/or aluminum container (unitized and ununitized or palletized and unpalletized) (sheets 1 through 18).	7-2

LIST OF TABLES

<i>Table Number</i>	<i>Title</i>	<i>Page</i>
2-1	Dimensions and Weights for STINGER Weapon System.	2-2
4-1	Tiedown Data for Unitized Package of Four STINGER Weapon Rounds or Missile Rounds in UH-1D/H Helicopters.	4-1
4-2	Tiedown Data for Unitized Package of Four STINGER Weapon Rounds or Missile Rounds in CH-47 Helicopter.	4-2
4-3	Tiedown Data for Unitized Package of Four STINGER Weapon Rounds or Missile Rounds in UH-60A Helicopter	4-2
4-4	Tiedown Data for Unitized Package of Four STINGER Weapon Rounds or Missile Rounds in CH-54 Universal Military Pod	4-2

CHAPTER 1

INTRODUCTION

1-1. Purpose and Scope

This manual provides transportability guidance for logistical movement of the STINGER weapon system components. It provides information to insure safe transport for worldwide moves of the system by air, highway, rail, and sea. Metric equivalent, as necessary, is given in parentheses following measurements.

1-2. Reporting of Recommendations and Comments

Individual users of this manual are encouraged to report errors and omissions and to make recommendations for improving it. Reports should be prepared on DA Form 2028 (Recommended Changes to DA Publications and Blank Forms) and forwarded to Director, Military Traffic Management Command Transportation Engineering Agency, ATTN: MTT-TRC, PO Box 6276, Newport News, VA 23606. (Electrically transmitted messages should be addressed to DIRMTMCTEA FT

EUSTIS VA//MTT-TRC//.) A reply will be furnished by the Agency.

1-3. Safety

Precautionary measures required during movement of the STINGER weapon system items are contained in chapter 3.

1-4. Definitions of Warnings, Cautions, and Notes

Throughout this manual, warnings, cautions, and notes emphasize important or critical guidance. They are used for the following conditions.

a. Warning. Instructions which, if not followed, could result in injury to or death of personnel.

b. Caution. Instructions which, if not strictly observed, could result in damage to, or destruction of equipment.

c. Note. A brief statement for use as necessary to emphasize a particular operating procedure, condition, and so forth.

CHAPTER 2

TRANSPORTABILITY DATA

Section I. GENERAL

2-1. Scope

This chapter provides a general description of the items, identification photographs, and tabulated transportability characteristics and data that are necessary for the movement of the complete STINGER weapon system, figure 2-1.

NOTE

Referenced figures appear at the end of this chapter.

2-2. Descriptions

a. The STINGER weapon round is one of a family of man portable air defense (MANPADS) weapons. The STINGER weapon round is a shoulder-fired, infrared homing missile. It consists of a missile and launch motor in a launch tube with a removable gripstock. The gripstock is removed from each fired weapon and used to fire the next missile. For each firing a battery coolant unit (BCU) is inserted into the gripstock. Three BCU's are supplied with the weapon round in each shipping and storage container. The complete STINGER weapon round in shipping and storage container is shown in figure 2-2.

b. The STINGER missile round consists of missile and launch motor in a launch tube, less the gripstock as shown in figure 2-3.

c. The identification friend or foe (IFF) interrogator set, AN/PPX-3, is transported in its shipping and storage container, figure 2-4. When in use the IFF is worn on a webb belt around the waist of the gunner.

d. Support equipment for the STINGER weapon system includes:

(1) IFF programmer set, AN/GSX-1 in Shipping and storage container, figure 2-5.

(2) Carry rack, an M4 transport harness,

designed to transport four weapon rounds and two missile rounds in the M416, 1/4-ton trailer, figure 2-6.

(3) Battery charger and batteries in shipping and storage container, figure 2-7.

(4) Field handling trainer, figure 2-7, is transported in weapon round shipping and storage container.

(5) Tracking head trainer, figure 2-7, is transported in weapon round shipping and storage container.

(6) IFF simulator, figure 2-7, is transported in IFF interrogator shipping and storage container.

(7) Gas pumping unit, figure 2-7, is transported without argon gas bottle shown in photograph.

(8) M151A2, 1/4-ton truck, and M416, 1/4-ton trailer, are used to transport command stock (four weapon rounds and two missile rounds) with each STINGER section gunner team assigned to combat units. The M151A2 truck is shown in figure 2-8.

2-3. General Transportation Policy

General transportation policy and security requirements for the STINGER Weapon System are identified by DOD 5100.76-M. Commercial carriers will move truck load (TL) shipments under continuous armed surveillance (driver and one other person, one of whom is armed) in a locked and sealed, exclusive-use vehicle. Less than truck-load (LTL) shipments will be moved under continuous armed surveillance (driver and one other person, one of whom is armed) with the cargo loaded in a locked and sealed dromedary, CONEX or a similar container with exclusive use. Similar security requirements apply to the other modes (rail, air and water) of transport. Classified material will be shipped in accordance with AR 380-5 and AR 55-355.

Section II. CHARACTERISTICS AND RELATED DATA OF ITEMS

2-4. General

The following data pertain to the identified items. Subsequent chapters show, where appropriate, dimensional data and weight for the items when

configured for movement by a particular mode of transportation.

NOTE

Data contained herein are applicable to

model number, National Stock Number (NSN), or configuration shown. Changes in model number, NSN, or configuration affect the loadability of the item as related to the guidance shown in this manual.

NOTE

Whenever weights and/or measurements are critical factors for transportability purposes, each item should be weighed and measured.

2-5. Dimensions

Dimensions and weights for STINGER weapon system items are shown in table 2-1.

2-6. CONUS Freight Classification

Rail and motor freight classification descriptions and item numbers will be determined in accordance with chapter 211, AR 55-355 and the freight classification guide system. Proper classification or description of articles must be determined and provided on the bill of lading before the shipment is released to the carrier.

Table 2-1. Dimensions and Weights for STINGER Weapon System

	Length	Width	Height	Weight
Guided Missile System, Intercept, Aerial (Weapon Round) (w/gripstock control and battery coolant unit) in Shipping and Storage Container	66.0 in.	13.0 in.	13.4 in.	85.75 LB
		(0.33 m)	(0.34 M)	(39 kg)
Missile Round, STINGER, complete	67.3 in.	13.1 in.	10.5 in.	77 lb
	(1.71 m)	(0.33 m)	(0.26 m)	(34 kg)
Interrogator, IFF, Kit, in Shipping and Storage Container AN/PPX-3	13.1 in.	9.9 in.	7.7 in.	11 lb
	(0.33 m)	(0.25 m)	(0.20 m)	(5 kg)
Programmer, Interrogator, Set in Shipping and Storage Container AN/GSX-1	16.8 IN.	9.6 in.	10.8 in.	29 lb
	(0.43 m)	(0.24 m)	(0.27 m)	(13 kg)
Harness, Guided Missile Equipment Transport XM-4	18.0 in.	18.0 in.	18.0 in.	7.0 lb
	(0.46 m)	(0.46 m)	(0.46 m)	(3 kg)
Trainer, Handling, Guided Missile Launcher XM60 w/Dummy Gripstock, BCU and IFF		13.6 in.	18.0 in.	83 lb
	(1.68 m)	(0.35 m)	(0.46 m)	(38 kg)
Recharging Unit, Coolant, Training Guided Missile System XM80 (contains argon gas, exempt per 173.306 (a) (1) Title 49 49CFR)	49.0 in.	50.0 in.	36.0 in.	500 lb
	(1.24 m)	(0.35 m)	(0.46 m)	(227 kg)
Trailer, Cargo, 1/4-Ton, M416 w/4 Weapon Rounds and 2 Missile		61.5 in.	44.0 in.	1,040 lb
	(2.76 m)	(1.56 m)	(1.12 m)	(472 kg)
Truck, Utility, 1/4-Ton, M151A2	131.5 in.	71.0 in.	73.8 in.	2,450 lb
	(3.34 m)	(1.80 m)	(1.88 m)	(1,111 kg)
	131.5 in.		525 in.	2,450 lb
	(3.34 m)	(1.63 m)	(1.33 m)	(1,111 kg)
Truck, Utility, 1/4-Ton, M151A2, Trailer, Cargo, 1/4-Ton, M416 w/4 Weapon Rounds and 2 Missile Rounds (reduced for air loading)	236.0 in.	64.0 in.	52.5 in.	3,490 lb
	(5.99 m)	(1.63 m)	(1.33 m)	(1,583 kg)

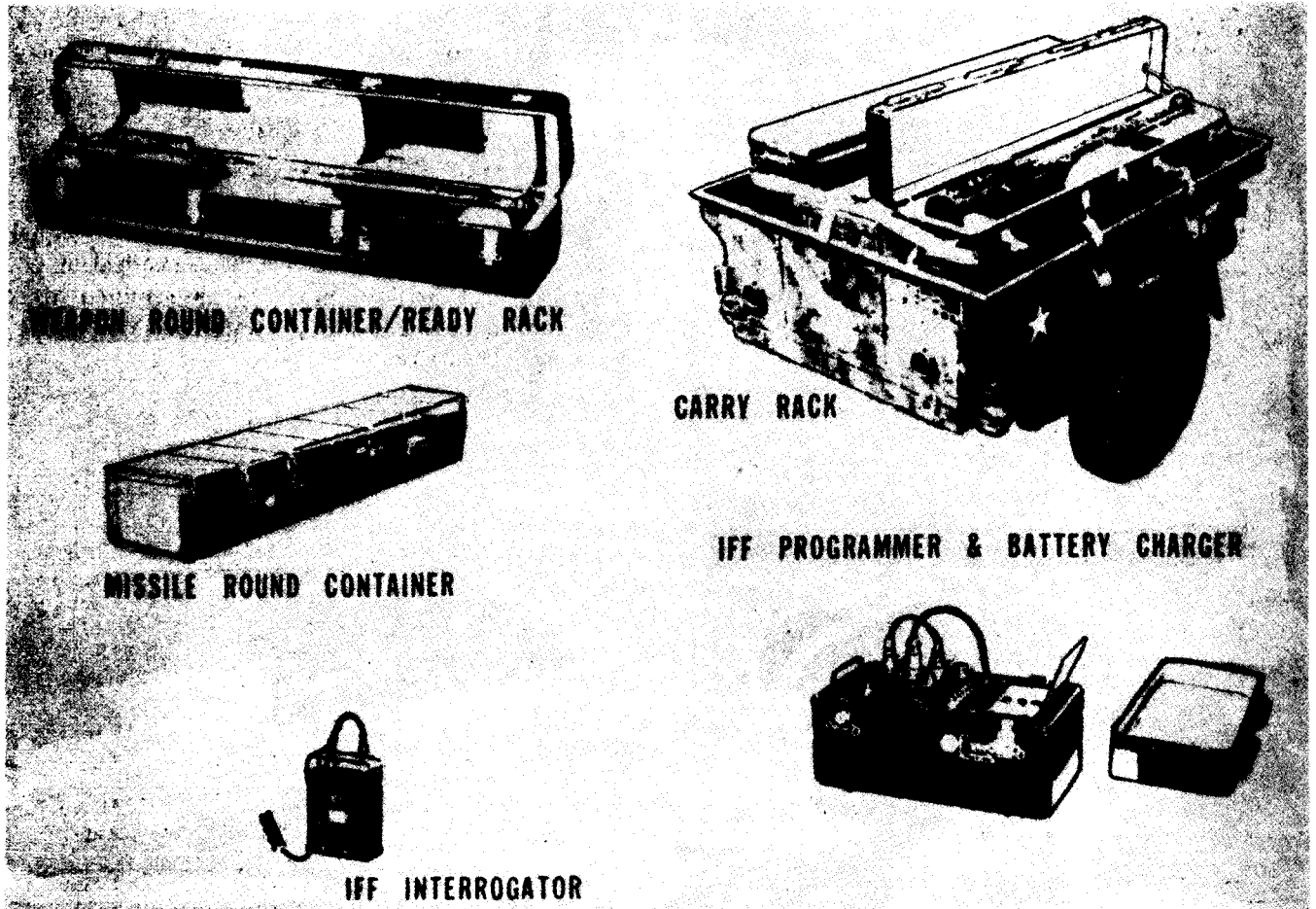

Figure 2-1. STINGER weapon system equipment.

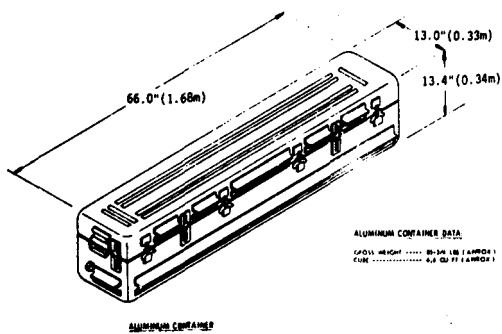
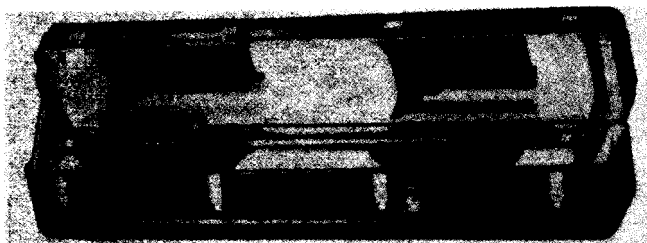

Figure 2-2. STINGER weapon round in shipping and storage container.

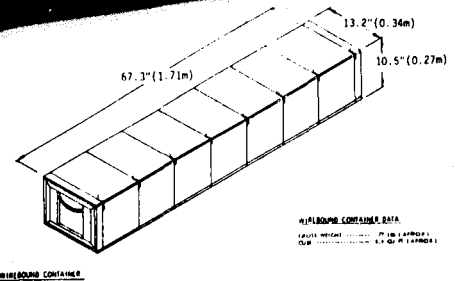
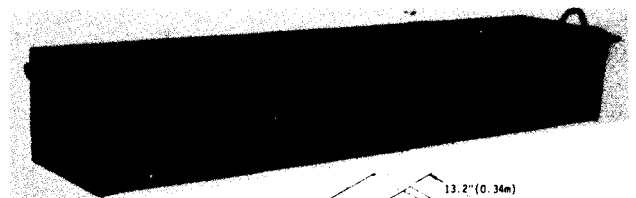

Figure 2-3. STINGER missile round in shipping and storage container.

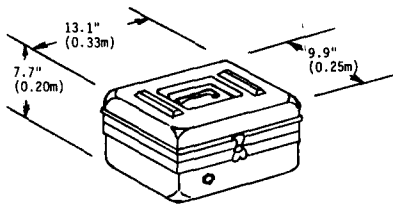
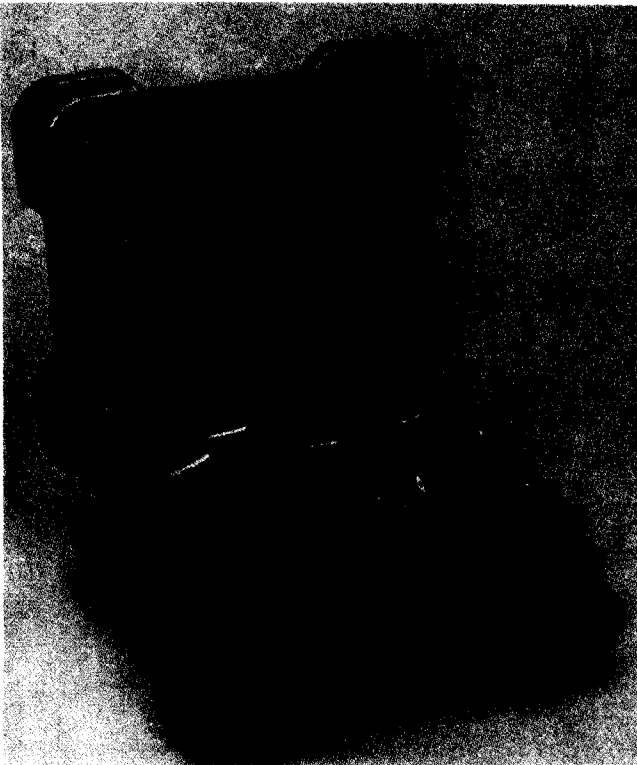

Figure 2-4. Identification Friend or Foe (IFF) interrogator set, AN/PPX-3, in shipping and storage container.

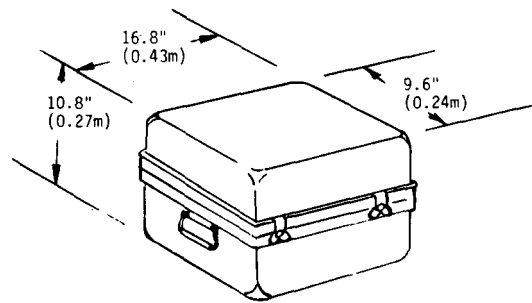
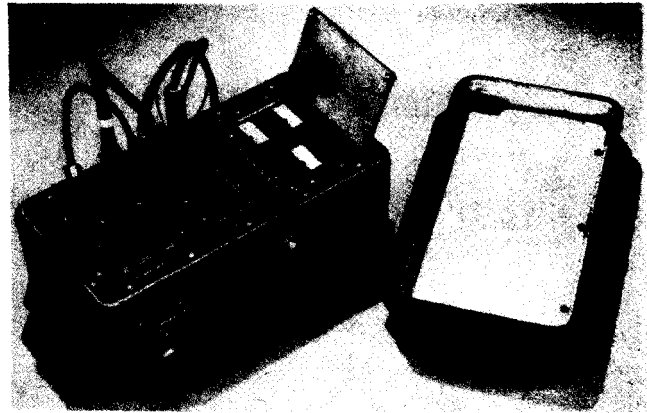

Figure 2-5. IFF programmer set, AN/GSX-1, in shipping and storage container.

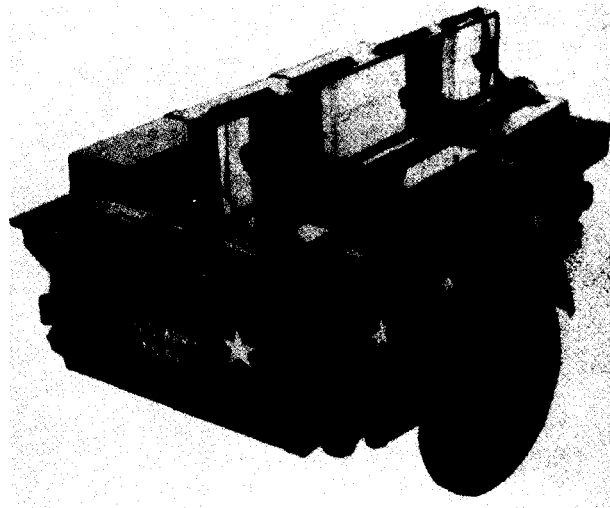

Figure 2-6. Carry rack for STINGER weapon rounds and missile rounds in M416, 1/4-ton trailer.

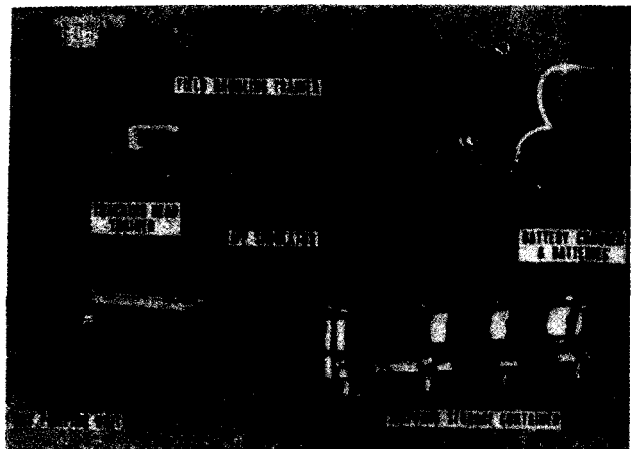

Figure 2-7. STINGER weapon system support equipment.

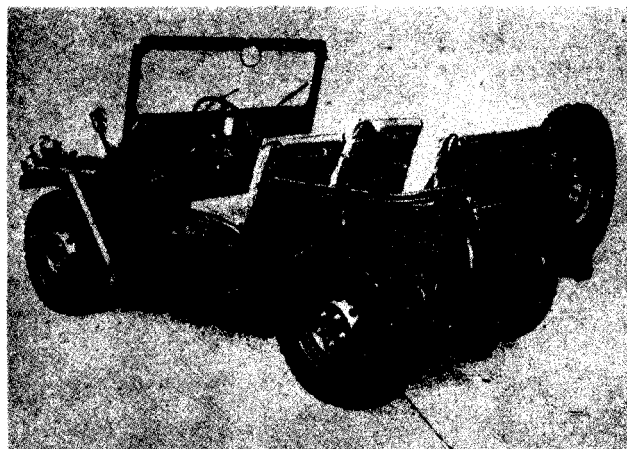

Figure 2-8. M151A2, 1/4-ton truck.

CHAPTER 3

SAFETY

3-1. General

General safety consideration and precautions for movement of the STINGER weapon system are as follows:

a. All modes of transport will comply with the requirements of Code of Federal Regulations, Title 49 (CFR 49).

b. Military air transport will comply with the provisions of Technical Manual (TM) 38-250/Air Force Regulation (AFR) 71-4.

3-2. Specific Safety Requirements

Pertinent safety requirements by individual mode can be found, where applicable, in the appropriate chapters.

CHAPTER 4

AIR TRANSPORTABILITY GUIDANCE

Section I. GENERAL

4-1. Scope

This chapter provides Department of the Army approved air transport procedures and guidance for

the movement of the STINGER weapon system components.

Section II. ARMY AIR TRANSPORT PROCEDURES

4-2. General

The procedures in this manual apply when the helicopter designated for the internal or external movement has an allowable cargo load capacity equal to or greater than the weight of the configured load. Loads described in this section are not maximum loads permissible for the packaged weapon round, missile round, M416 trailer, or the M151A2 truck.

4-3. External Transport

a. Nine weapon rounds and/or missile rounds or any combination thereof may be externally transported in an A-22 aerial delivery bag. The items may be individually stacked or banded together in a unitized package. Assemble the load as shown in figure 4-1.

NOTE: Referred figures appear at the end of this chapter.

b. External rigging and transport procedures for the M151 truck and M416 trailer are given in TM 55-450-11.

4-4. Internal Transport

a. A unitized package of four weapon rounds or missile rounds are shown for the UH-1, CH-47, UH-60 and CH-54, in figures 4-2, 4-3, 4-4, and 4-5 respectively, as typical procedures and tiedown techniques. As stated in paragraph 4-2, these do not represent maximum loads. Tiedown data are given in tables 4-1, 4-2, 4-3, and 4-4 respectively.

b. Internal loading and transport for the M151 truck and M416 trailer are given in the general loading instructions in each operator's manual for the CH-47 and CH-54 helicopters.

c. The STINGER weapon system may be packaged, placed in various unitized package configurations, for air delivery as shown in figure 4-6.

NOTE

Figure 4-6 is extracted from US Army Development and Research Command missile drawings. References to page numbers in the notes within the figure refer to the number listed in the lower right-hand or left-hand corner of each figure.

Table 4-1. Tiedown Data for Unitized Package of Four STINGER Weapon Rounds or Missile Rounds in UH-1D/H Helicopters

Tiedown fitting designation	Tiedown fitting capacity in 1,000 lb	Tiedown device		Attach to item
		type	capacity in 1,000 lb	
C1	1.25	CGU-1/B	5	Attach ratchet end and pass hook end through top rear container handle, around rear of top container, through opposite end handle, and attach to tiedown fitting C2.
H1	1.25	CGU-1/B	5	Attach ratchet end and pass hook end through top forward container handle around front of top container, through opposite end handle, and attach to tiedown fitting H2.
D1	1.25	CGU-1/B	5	Pass over top of forward container to tiedown fitting D6.
E1	1.25	CGU-1/B	5	Pass over top of rear container to tiedown fitting E4.

Table 4-2. Tiedown Data for Unitized Package of Four STINGER
Weapon Rounds or Missile Rounds in CH-47 Helicopter

<i>designation</i>	<i>Tiedown fitting capacity in 1,000 lb</i>	<i>Tiedown device type</i>	<i>Tiedown device capacity in 1,000 lb</i>	<i>Attach to item</i>
B7	5	CGU-1/B	5	Attach ratchet end and pass hook end through top rear container handle, around rear of top container, through opposite end handle, and attach to tiedown fitting D7.
B11	5	CGU-1/B	5	Attach ratchet end and pass hook end through top forward container handle, around front of top container, through opposite end handle, and attach to tiedown fitting D11.

Table 4-3. Tiedown Data for Unitized Package of Four STINGER
Weapon Rounds or Missile Rounds in UH-60A Helicopter

<i>designation</i>	<i>Tiedown fitting capacity in 1,000 lb</i>	<i>Tiedown device type</i>	<i>Tiedown device capacity in 1,000 lb</i>	<i>Attach to item</i>
C2	5	CGU-1/B	5	Attach ratchet end and pass hook end through top rear container handle, around rear of top container, through opposite end handle and attach to tiedown fitting E2.
B5	5	CGU-1/B	5	Attach ratchet end and pass hook end through top forward container handle, around front of top container, through opposite end handle and attach to tiedown fitting 5.
C3	5	CGU-1/B	5	Over top of containers to tiedown fitting C4.
E3	5	CGU-1/B	6	Over top of containers to tiedown fitting E4.

Table 4-4. Tiedown Data for Unitized Package of Four STINGER
Weapon Rounds or Missile Rounds in CH-54 Military Universal Pod

<i>designation</i>	<i>Tiedown fitting capacity in 1,000 lb</i>	<i>Tiedown device type</i>	<i>Tiedown device capacity in 1,000 lb</i>	<i>Attach to item</i>
C7	5	CGU-1/B	5	Attach ratchet end and pass hook end through top rear container handle, around rear of top container, through opposite end handle, and attach to tiedown fitting D7.
C11	5	CGU-1/B	5	Attach ratchet end and pass hook end through top forward container handle, around front of top container, through opposite end handle, and attach to tiedown fitting D11.

Section III. TRANSPORT BY US AIR FORCE AIRCRAFT

4-5. General

The STINGER weapon system components may be pallet loaded or vehicle loaded on US Air Force aircraft provided the load complies with the provisions of TM 38-250/AFR 71-4 for hazardous

materials. The STINGER load must be compatible with other cargo to be shipped on the same aircraft. Loading procedures are as shown in the general loading instructions of each Technical Order dash 9 for the aircraft to be loaded.

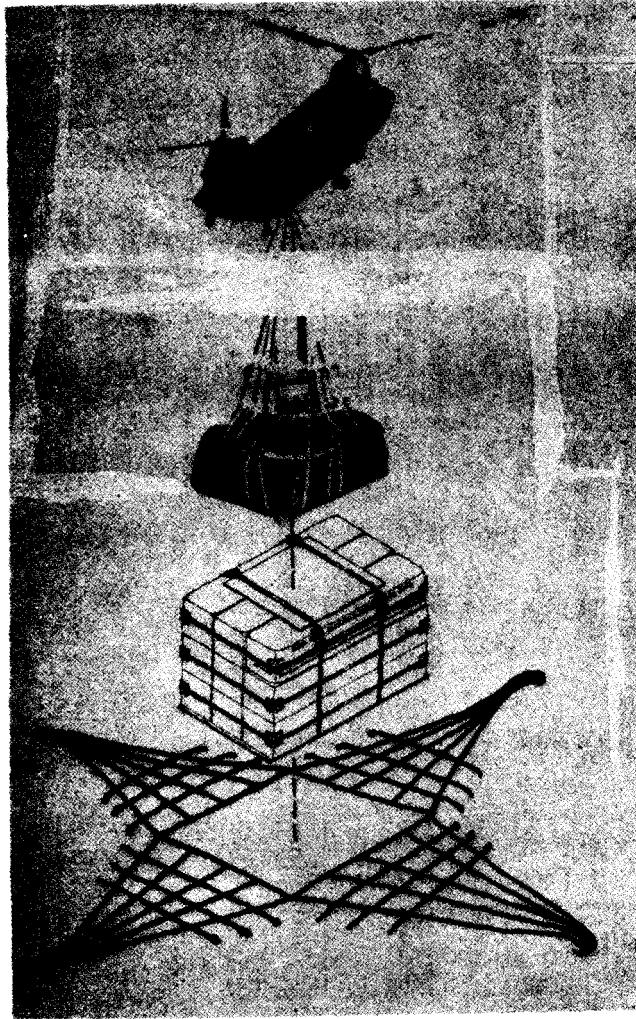
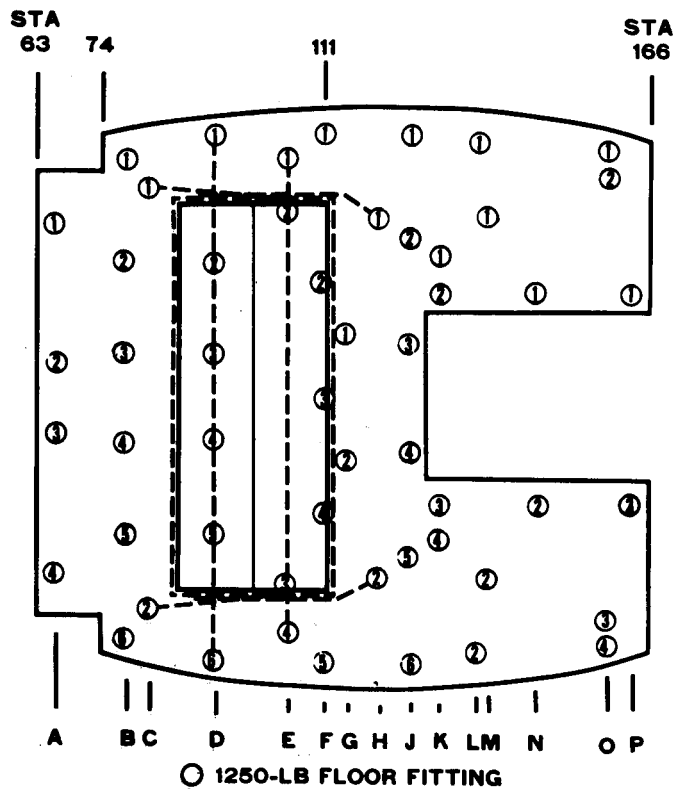
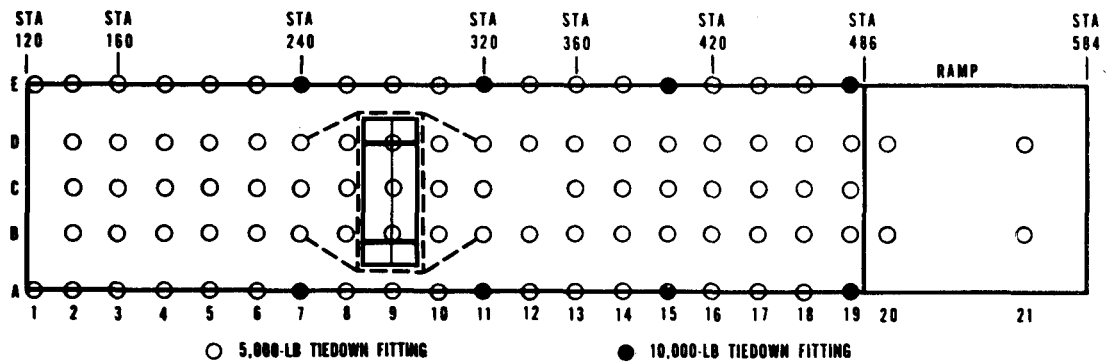

Figure 4-1. Assembly of nine STINGER weapon rounds or STINGER missile rounds in an A-22 aerial delivery bag for external transport by helicopter.



ITEM	DESCRIPTION OF ITEM	ITEM FACING	LOCATION OF REFERENCE POINT		LOCATION OF CG (STA)	APPROX WT (LB)
			REFERENCE POINT	STATION		
1	FOUR STINGER WEAPON ROUNDS OR FOUR STINGER MISSILE ROUNDS	SIDE	FWD SIDE	87	100	344
		SIDE	FWD SIDE	87	100	308

Figure 4-2. Unitized package of four STINGER weapon rounds or missile rounds in UH-1D helicopter.



NOTE: UTILITY HATCH DOOR IS LOCATED IN THE CENTER OF THE FLOOR BETWEEN STATIONS 320 AND 360

ITEM	DESCRIPTION OF ITEM	ITEM FACING	LOCATION OF REFERENCE POINT		LOCATION OF CG (STA)	APPROX WT (LB)
			REFERENCE POINT	STATION		
1	FOUR STINGER WEAPON ROUNDS OR FOUR STINGER MISSILE ROUNDS	SIDE	FWD SIDE	267	280	344
		SIDE	FWD SIDE	267	280	308

Figure 4-3. Unitized package of four STINGER weapon rounds or missile rounds in CH-47 helicopter.

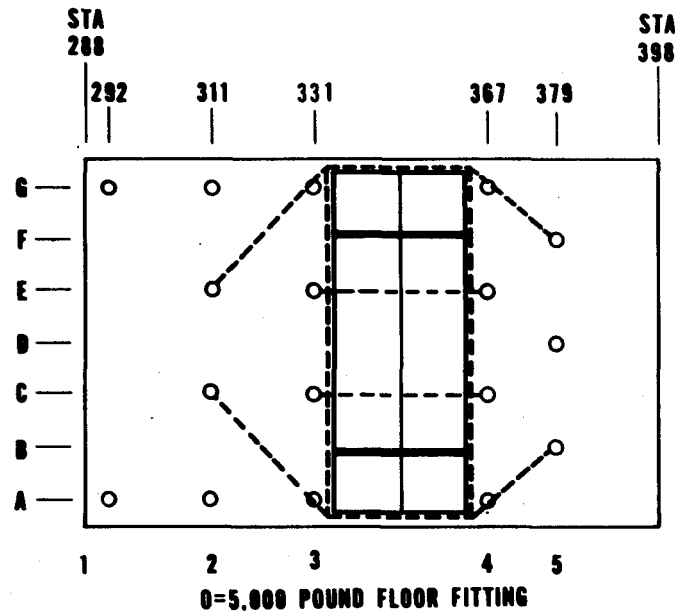

ITEM	DESCRIPTION OF ITEM	ITEM FACING	LOCATION OF REFERENCE POINT		LOCATION OF CG (STA)	APPROX WT (LB)
			REFERENCE POINT	STATION		
1	FOUR STINGER WEAPON ROUNDS OR FOUR STINGER MISSILE ROUNDS	SIDE	FWD SIDE	336	349	344

Figure 4-4. Unitized package of four STINGER weapon rounds or missile rounds, on 1/4-inch plywood, in UH-60A helicopter.

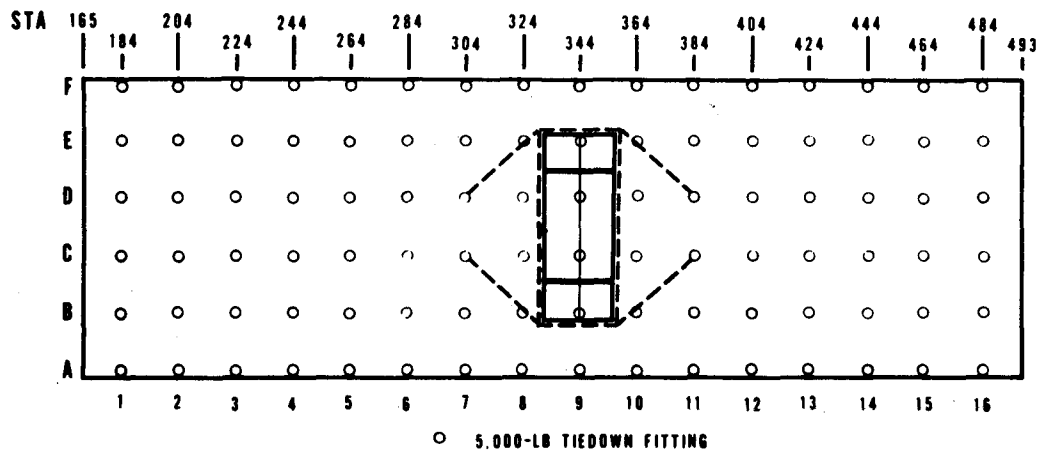

ITEM	DESCRIPTION OF ITEM	ITEM FACING	LOCATION OF REFERENCE POINT		LOCATION OF CG (STA)	APPROX WT (LB)
			REFERENCE POINT	STATION		
1	FOUR STINGER WEAPON ROUNDS OR FOUR STINGER MISSILE ROUNDS	SIDE	FWD SIDE	331	344	344
		SIDE	FWD SIDE	331	344	308

Figure 4-5. Unitized package of four STINGER weapon rounds or missile rounds in CH-54 universal military pod.

GENERAL NOTES

- A. NA
- B. THE PALLETIZATION PROCEDURES SPECIFIED IN THIS DRAWING ARE APPLICABLE TO THE STINGER GUIDED MISSILE PACKED IN WIREBOUND CONTAINER AND/OR ALUMINUM CONTAINER. SUBSEQUENT REFERENCE TO CONTAINER MEANS WIREBOUND CONTAINER AND/OR ALUMINUM CONTAINER WITH CONTENTS.
- C. FOR DETAILS OF THE WIREBOUND CONTAINER, SEE US ARMY MISSILE COMMAND DRAWING NO. 1150P503 AND "CONTAINER" DETAIL ON PAGE 3.
- CONTAINER DIMENSIONS-- 67-1/4" LONG X 13-1/8" WIDE X 10-1/2" HIGH
(APPROX).
GROSS WEIGHT ----- 77 POUNDS (APPROX).
CUBE ----- 5.4 CUBIC FEET.
- D. FOR DETAILS OF THE ALUMINUM CONTAINER, SEE US ARMY MISSILE COMMAND DRAWING NO. 1148P52 AND "CONTAINER" DETAIL ON PAGE 3.
- CONTAINER DIMENSIONS-- 65-9/16" LONG X 13" WIDE X 13-3/8" HIGH
(APPROX).
GROSS WEIGHT ----- 85-3/4 POUNDS (APPROX).
CUBE ----- 6.6 CUBIC FEET.
- E. **CAUTION:** THIS ITEM MUST BE POSITIONED ON THE PALLET WITH FORWARD END OF ALL CONTAINERS POINTING IN THE SAME DIRECTION.
- F. WHEN STEEL STRAPPING IS SEALED AT AN END-OVER-END LAP JOINT, A MINIMUM OF TWO (2) SEALS, BUTTED TOGETHER, WITH TWO (2) PAIR OF CRIMPS PER SEAL MUST BE USED TO SEAL THE JOINT.
- G. IN ORDER TO OBTAIN COMPACT (SOUND) UNITS, ALL STRAPS SHALL BE LOCATED IN PROPER ALIGNMENT AND TENSIONED UNTIL THEY CUT INTO THE EDGE OF THE DUNNAGE/BOXES AND THE PALLET DECK.

19-48-5240-GM20SR2 March 1979

MATERIAL SPECIFICATIONS

- PLYWOOD** ----- : GROUP B OR C, GRADE C-D, FED SPEC NN-1-P-530.
- HONEYCOMB PAD** ---- : MIL SPEC MIL-H-9084.
- FIBERBOARD PAD** ---- : TYPE I, FED SPEC PPP-F-320.
- STRAPPING STEEL** ---- : CLASS I, TYPE I OR IV, HEAVY DUTY, FINISH A OR B (GRADE 2), FED SPEC QQ-6-781.
- SEAL STRAP** ----- : TYPE D, STYLE I, II, OR IV, CLASS H, FED SPEC QQ-6-781.
- ADHESIVE, SYNTHETIC RUBBER** ----- : TYPE, COLD BONDING, FED SPEC MMM-A-189.

PAGE 2

Sheet 1 of 10

Figure 4-6. Preparation of the complete STINGER weapon round packed in wirebound and/or aluminum container for aerial delivery (sheets 1 through 10).

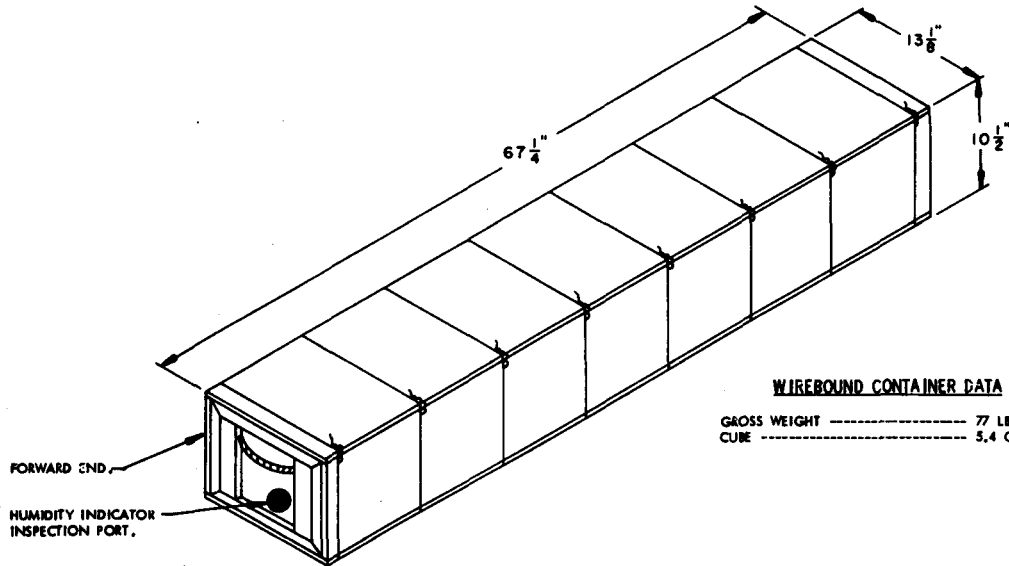

WIREBOUND CONTAINER DATA

GROSS WEIGHT ----- 77 LBS (APPROX).
CUBE ----- 5.4 CU FT (APPROX).

WIREBOUND CONTAINER

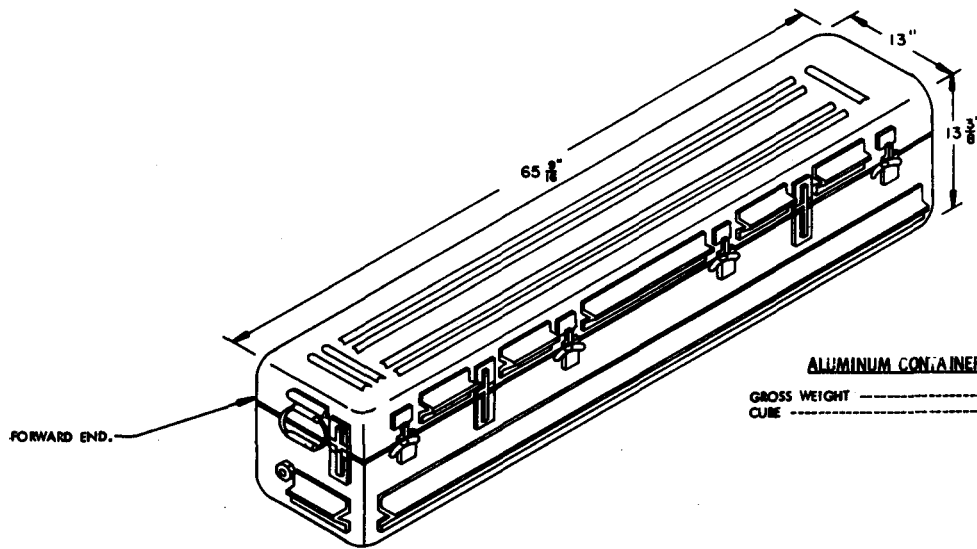

ALUMINUM CONTAINER DATA

GROSS WEIGHT ----- 85-3/4 LBS (APPROX).
CUBE ----- 6.6 CU FT (APPROX).

ALUMINUM CONTAINER

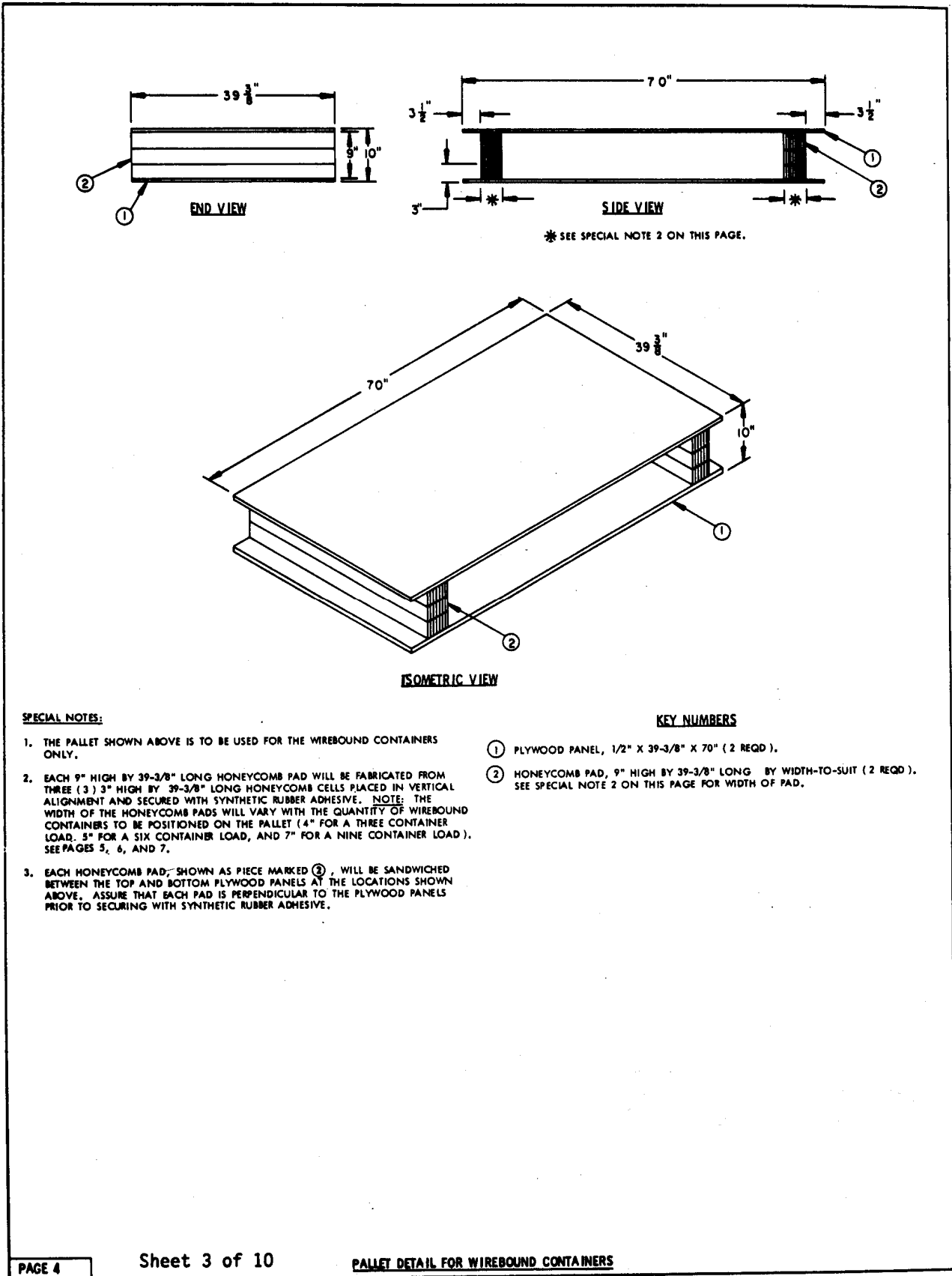

SPECIAL NOTES:

1. THE PALLET SHOWN ABOVE IS TO BE USED FOR THE WIREBOUND CONTAINERS ONLY.
2. EACH 9" HIGH BY 39-3/8" LONG HONEYCOMB PAD WILL BE FABRICATED FROM THREE (3) 3" HIGH BY 39-3/8" LONG HONEYCOMB CELLS PLACED IN VERTICAL ALIGNMENT AND SECURED WITH SYNTHETIC RUBBER ADHESIVE. NOTE: THE WIDTH OF THE HONEYCOMB PADS WILL VARY WITH THE QUANTITY OF WIREBOUND CONTAINERS TO BE POSITIONED ON THE PALLET (4" FOR A THREE CONTAINER LOAD, 5" FOR A SIX CONTAINER LOAD, AND 7" FOR A NINE CONTAINER LOAD). SEE PAGES 5, 6, AND 7.
3. EACH HONEYCOMB PAD, SHOWN AS PIECE MARKED ②, WILL BE SANDWICHED BETWEEN THE TOP AND BOTTOM PLYWOOD PANELS AT THE LOCATIONS SHOWN ABOVE. ASSURE THAT EACH PAD IS PERPENDICULAR TO THE PLYWOOD PANELS PRIOR TO SECURING WITH SYNTHETIC RUBBER ADHESIVE.

KEY NUMBERS

- ① PLYWOOD PANEL, 1/2" X 39-3/8" X 70" (2 REQD).
- ② HONEYCOMB PAD, 9" HIGH BY 39-3/8" LONG BY WIDTH-TO-SUIT (2 REQD). SEE SPECIAL NOTE 2 ON THIS PAGE FOR WIDTH OF PAD.

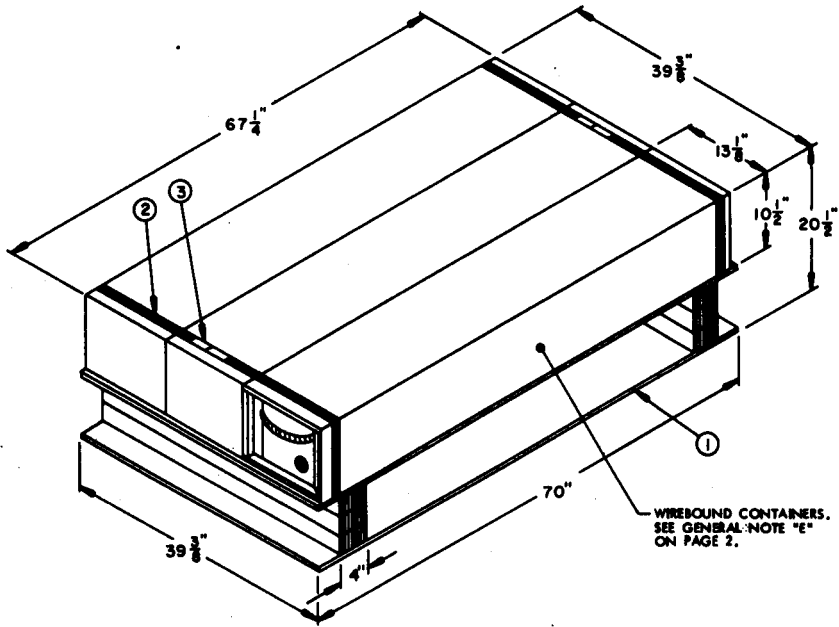

PALLETIZED UNIT

UNIT DATA

WIREBOUND (WOODEN) BOX	— 3 EACH @ 77 POUNDS —	231 LBS
DUNNAGE (STRAPPING ONLY)	—————	3 LBS
PALLET (PLYWOOD ONLY)	—————	53 LBS
TOTAL WEIGHT	—————	287 LBS (APPROX)
CUBE	—————	32.70 CU FT (APPROX)

KEY NUMBERS

- ① PALLET (1 REQD). SEE THE "PALLET DETAIL FOR WIREBOUND CONTAINERS" ON PAGE 4.
- ② STEEL STRAPPING, 1-1/4" X .035" X 10'-0" LONG (2 REQD). POSITION NEAR EACH END OF THE WIREBOUND CONTAINER AS SHOWN ABOVE. SEE GENERAL NOTE "G" ON PAGE 2.
- ③ SEAL FOR 1-1/4" STRAPPING (4 REQD, 2 PER STRAP). CRIMP EACH SEAL WITH TWO PAIR OF NOTCHES. SEE GENERAL NOTE "H" ON PAGE 2.

BILL OF MATERIAL

ITEM	REQUIRED	POUNDS
PLYWOOD, 1/2" THICK	38.28 SQ FT	52.06
HONEYCOMB CELL	6 REQD	NIL
STEEL STRAPPING, 1-1/4"	20 FT	2.85
SEAL FOR 1-1/4" STRAPPING	4 REQD	NIL

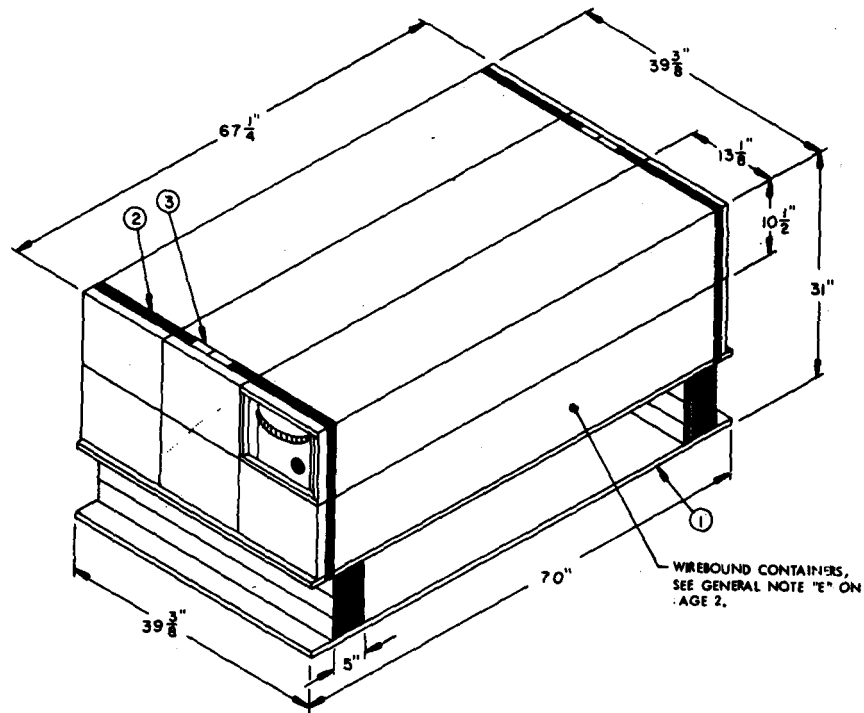

PALLETIZED UNIT

UNIT DATA

WIREBOUND (WOODEN) BOX - 6 EACH @ 77 POUNDS	462 LBS
DUNNAGE (STRAPPING ONLY)	4 LBS
PALLET (PLYWOOD ONLY)	53 LBS
TOTAL WEIGHT	519 LBS (APPROX)
CUBE	49.50 CU FT (APPROX)

KEY NUMBERS

- ① PALLET (1 REQD). SEE THE "PALLET DETAIL FOR WIREBOUND CONTAINERS" ON PAGE 4.
- ② STEEL STRAPPING, 1-1/4" X .035" X 12'-0" LONG (2 REQD). POSITION NEAR EACH END OF THE WIREBOUND CONTAINERS AS SHOWN ABOVE. SEE GENERAL NOTE "G" ON PAGE 2.
- ③ SEAL FOR 1-1/4" STRAPPING (4 REQD, 2 PER STRAP). CRIMP EACH SEAL WITH TWO PAIR OF NOTCHES. SEE GENERAL NOTE "F" ON PAGE 2.

BILL OF MATERIAL

ITEM	REQUIRED	POUNDS
PLYWOOD, 1/2" THICK HONEYCOMB CELL	38.28 SQ FT.	52.06
STEEL STRAPPING, 1-1/4"	6 REQD	NIL
SEAL FOR 1-1/4" STRAPPING	24 FT	3.43
	4 REQD	NIL

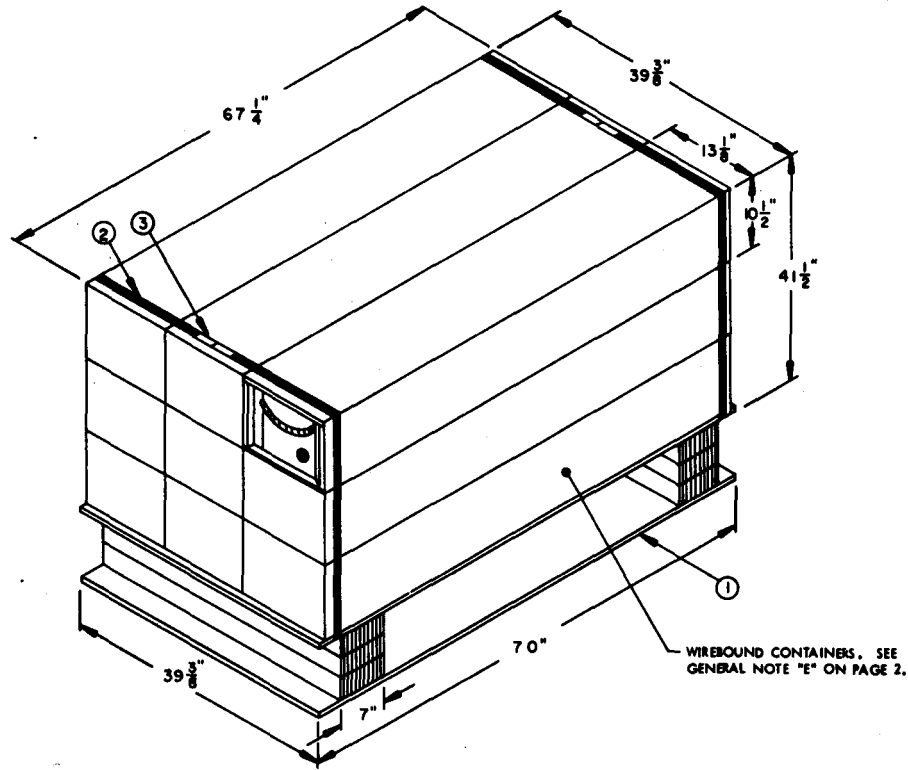

PALLETIZED UNIT

UNIT DATA

WIREBOUND (WOODEN) BOX - 9 EACH @ 77 POUNDS	--	693 LBS
DUNNAGE (STRAPPING ONLY)	-----	4 LBS
PALLET (PLYWOOD ONLY)	-----	53 LBS
<hr/>		
TOTAL WEIGHT	-----	750 LBS (APPROX)
CUBE	-----	66.20 CU FT (APPROX)

KEY NUMBERS

- ① PALLET (1 REQD). SEE THE "PALLET DETAIL FOR WIREBOUND CONTAINERS" ON PAGE 4.
- ② STEEL STRAPPING, 1-1/4" X .035" X 14'-0" LONG (2 REQD). POSITION NEAR EACH END OF THE WIREBOUND CONTAINERS AS SHOWN ABOVE. SEE GENERAL NOTE "G" ON PAGE 2.
- ③ SEAL FOR 1-1/4" STRAPPING (4 REQD, 2 PER STRAP). CRIMP EACH SEAL WITH TWO PAIR OF NOTCHES. SEE GENERAL NOTE "F" ON PAGE 2.

BILL OF MATERIAL

ITEM	REQUIRED	POUNDS
PLYWOOD, 1/2" THICK HONEYCOMB CELL	36.28 SQ FT	52.06
STEEL STRAPPING, 1-1/4" SEAL FOR 1-1/4" STRAPPING	4 REQD	NIL
	28 FT	4.00
	4 REQD	NIL

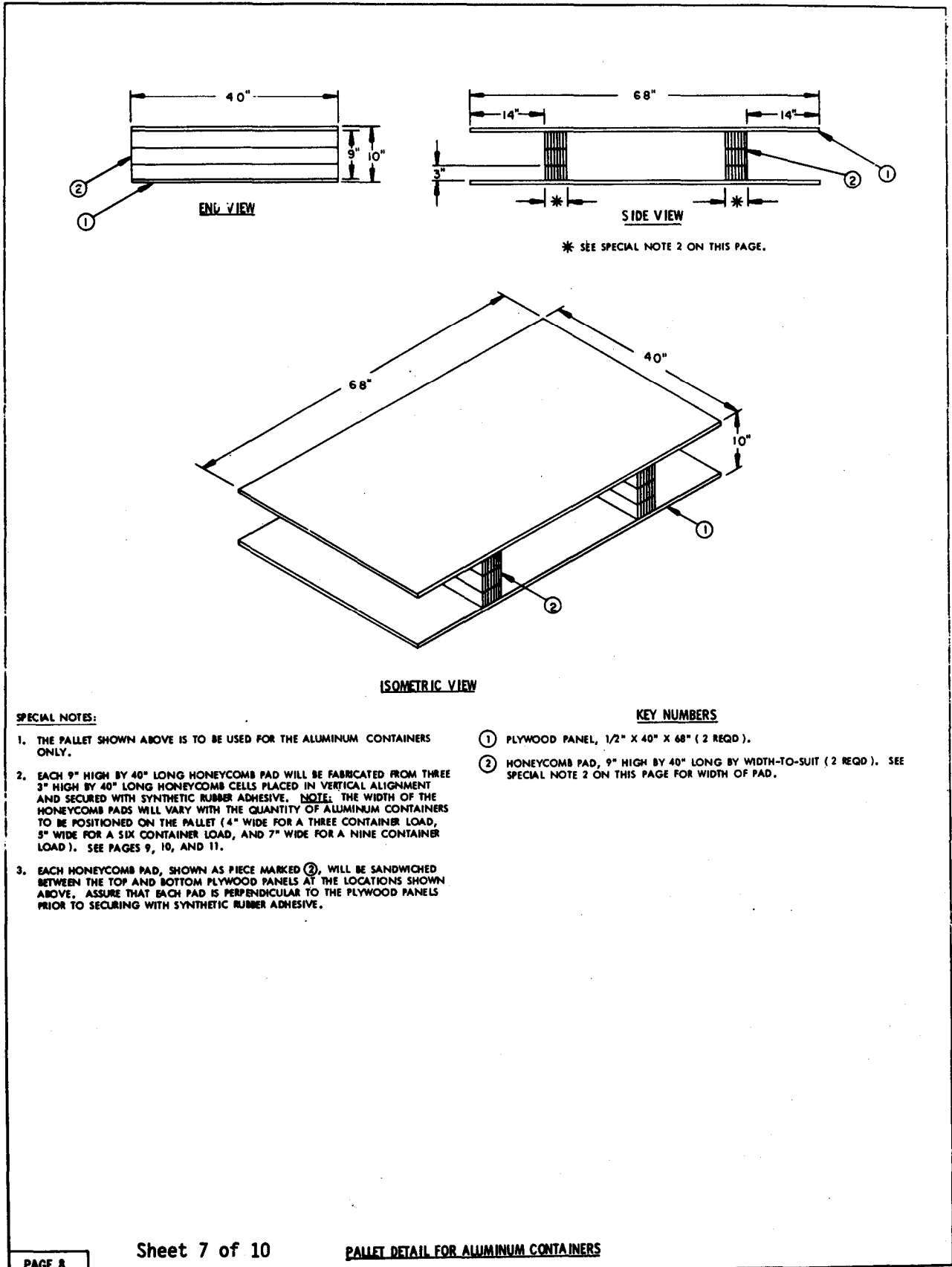

SPECIAL NOTES:

1. THE PALLET SHOWN ABOVE IS TO BE USED FOR THE ALUMINUM CONTAINERS ONLY.
2. EACH 9" HIGH BY 40" LONG HONEYCOMB PAD WILL BE FABRICATED FROM THREE 3" HIGH BY 40" LONG HONEYCOMB CELLS PLACED IN VERTICAL ALIGNMENT AND SECURED WITH SYNTHETIC RUBBER ADHESIVE. **NOTE:** THE WIDTH OF THE HONEYCOMB PADS WILL VARY WITH THE QUANTITY OF ALUMINUM CONTAINERS TO BE POSITIONED ON THE PALLET (4" WIDE FOR A THREE CONTAINER LOAD, 5" WIDE FOR A SIX CONTAINER LOAD, AND 7" WIDE FOR A NINE CONTAINER LOAD). SEE PAGES 9, 10, AND 11.
3. EACH HONEYCOMB PAD, SHOWN AS PIECE MARKED ②, WILL BE SANDWICHED BETWEEN THE TOP AND BOTTOM PLYWOOD PANELS AT THE LOCATIONS SHOWN ABOVE. ASSURE THAT EACH PAD IS PERPENDICULAR TO THE PLYWOOD PANELS PRIOR TO SECURING WITH SYNTHETIC RUBBER ADHESIVE.

KEY NUMBERS

- ① PLYWOOD PANEL, 1/2" X 40" X 68" (2 REQD).
- ② HONEYCOMB PAD, 9" HIGH BY 40" LONG BY WIDTH-TO-SUIT (2 REQD). SEE SPECIAL NOTE 2 ON THIS PAGE FOR WIDTH OF PAD.

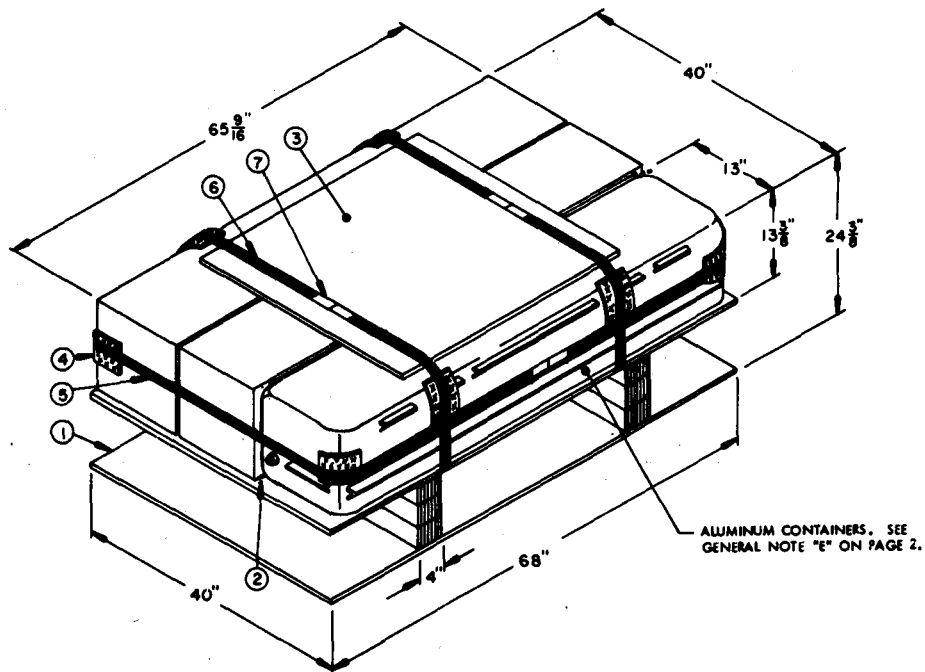

PALLETIZED UNIT

UNIT DATA

ALUMINUM CONTAINER - 3 EACH @ 86 POUNDS	-----	258 LBS
DUNNAGE (STRAPPING, SPACERS, AND FIBERBOARD)	-----	34 LBS
PALLET (PLYWOOD ONLY)	-----	52 LBS
TOTAL WEIGHT	-----	344 LBS (APPROX)
CUBE	-----	38.37 CU FT (APPROX)

KEY NUMBERS

- ① PALLET (1 REQD). SEE THE "PALLET DETAIL FOR ALUMINUM CONTAINERS" ON PAGE 8.
- ② SPACER, PLYWOOD, 1/2" X 13" X 60" (2 REQD). POSITION ON EDGE BETWEEN CONTAINERS AS SHOWN.
- ③ FIBERBOARD PAD, 1" X 34" X 36" (1 REQD). POSITION ON TOP OF CONTAINERS AS SHOWN ABOVE.
- ④ FIBERBOARD PAD, 1/2" X 4" X 6" (8 REQD). POSITION UNDER STEEL STRAPPING AT THE LOCATIONS SHOWN ABOVE.
- ⑤ STEEL STRAPPING, 1-1/4" X .035" X 19'-0" LONG (1 REQD). POSITION TO ENCIRCLE ALL THREE CONTAINERS AS SHOWN ABOVE.
- ⑥ STEEL STRAPPING, 1-1/4" X .035" X 10'-0" LONG (2 REQD). POSITION AS SHOWN ABOVE. SEE GENERAL NOTE "G" ON PAGE 2.
- ⑦ SEAL FOR 1-1/4" STRAPPING (6 REQD, 2 PER STRAP). CRIMP EACH SEAL WITH TWO PAIR OF NOTCHES. SEE GENERAL NOTE "F" ON PAGE 2.

BILL OF MATERIAL

ITEM	REQUIRED	POUNDS
PLYWOOD, 1/2" THICK	48.61 SQ FT	66.11
FIBERBOARD, 1" THICK	8.30 SQ FT	12.75
FIBERBOARD, 1/2" THICK	AS REQD	NIL
HONEYCOMB CELL	6 REQD	NIL
STEEL STRAPPING, 1-1/4"	39 FT	5.30
SEAL FOR 1-1/4" STRAPPING	6 REQD	NIL

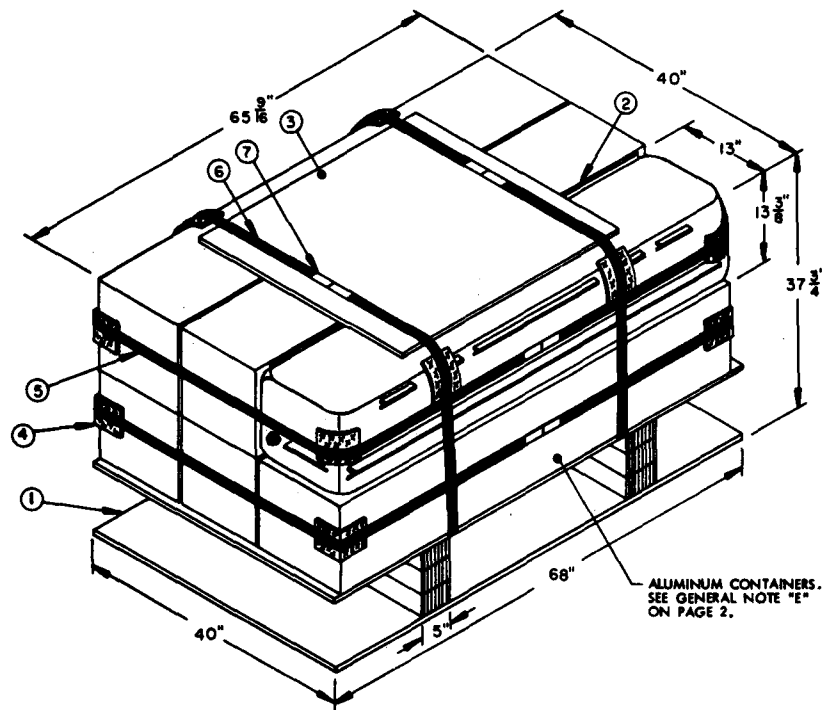

ALUMINUM CONTAINERS.
SEE GENERAL NOTE "E"
ON PAGE 2.

PALLETIZED UNIT

UNIT DATA

ALUMINUM CONTAINER — 4 EACH @ 86 POUNDS	316 LBS
DUNNAGE (STRAPPING, SPACERS, AND FIBERBOARD)	51 LBS
PALLET (PLYWOOD ONLY)	52 LBS
TOTAL WEIGHT	419 LBS (APPROX)
CUBE	99.42 CU FT (APPROX)

KEY NUMBERS

- ① PALLET (1 REQD). SEE THE "PALLET DETAIL FOR ALUMINUM CONTAINERS" ON PAGE 8.
- ② SPACER, PLYWOOD, 1/2" X 26" X 60" (2 REQD). POSITION ON EDGE BETWEEN CONTAINERS AS SHOWN.
- ③ FIBERBOARD PAD, 1" X 34" X 36" (1 REQD). POSITION ON TOP OF CONTAINERS AS SHOWN ABOVE.
- ④ FIBERBOARD PAD, 1/2" X 4" X 6" (12 REQD). POSITION UNDER STEEL STRAPPING AT THE LOCATIONS SHOWN ABOVE.
- ⑤ STEEL STRAPPING, 1-1/4" X .035" X 19'-0" LONG (2 REQD). POSITION EACH STRAP TO ENCIRCLE THREE CONTAINERS AS SHOWN ABOVE.
- ⑥ STEEL STRAPPING, 1-1/4" X .035" X 12'-0" LONG (2 REQD). POSITION AS SHOWN ABOVE. SEE GENERAL NOTE "G" ON PAGE 2.
- ⑦ SEAL FOR 1-1/4" STRAPPING (8 REQD, 2 PER STRAP). CRIMP EACH SEAL WITH TWO PAIR OF NOTCHES. SEE GENERAL NOTE "F" ON PAGE 2.

BILL OF MATERIAL

ITEM	REQUIRED	POUNDS
PLYWOOD, 1/2" THICK	40.14 SQ FT	81.80
FIBERBOARD, 1" THICK	8.30 SQ FT	12.75
FIBERBOARD, 1/2" THICK	AS REQD	NIL
HONEYCOMB CELL	6 REQD	NIL
STEEL STRAPPING, 1-1/4"	42 FT	8.86
SEAL FOR 1-1/4" STRAPPING	8 REQD	NIL

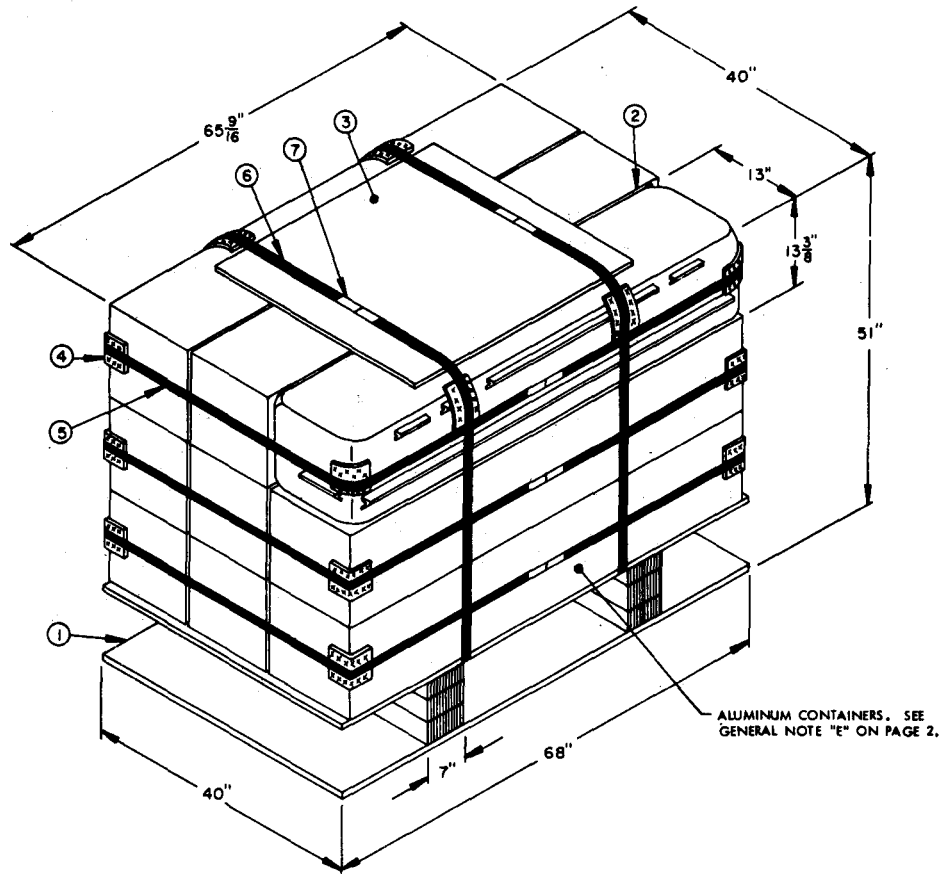

PALLETIZED UNIT

UNIT DATA

ALUMINUM CONTAINER - 9 EACH @ 86 POUNDS	-----	774 LBS
DUNNAGE (STRAPPING, SPACERS, AND FIBERBOARD)	-----	69 LBS
PALLET (PLYWOOD ONLY)	-----	52 LBS
TOTAL WEIGHT	-----	895 LBS (APPROX)
CUBE	-----	80.30 CU FT (APPROX)

KEY NUMBERS

- ① PALLET (1 REQD). SEE THE "PALLET DETAIL FOR ALUMINUM CONTAINERS" ON PAGE 8.
- ② SPACER, PLYWOOD, 1/2" X 39" X 60" (2 REQD). POSITION ON EDGE BETWEEN CONTAINERS AS SHOWN.
- ③ FIBERBOARD PAD, 1" X 34" X 36" (1 REQD). POSITION ON TOP OF CONTAINERS AS SHOWN ABOVE.
- ④ FIBERBOARD PAD, 1/2" X 4" X 6" (16 REQD). POSITION UNDER STEEL STRAPPING AT THE LOCATIONS SHOWN ABOVE.
- ⑤ STEEL STRAPPING, 1-1/4" X .035" X 19'-0" LONG (3 REQD). POSITION EACH STRAP TO ENCIRCLE THREE CONTAINERS AS SHOWN ABOVE.
- ⑥ STEEL STRAPPING, 1-1/4" X .035" X 14'-0" LONG (2 REQD). POSITION AS SHOWN ABOVE. SEE GENERAL NOTE "G" ON PAGE 2.
- ⑦ SEAL FOR 1-1/4" STRAPPING (10 REQD, 2 PER STRAP). CRIMP EACH SEAL WITH TWO PAIR OF NOTCHES. SEE GENERAL NOTE "F" ON PAGE 2.

BILL OF MATERIAL

ITEM	REQUIRED	POUNDS
PLYWOOD, 1/2" THICK	70.30 SQ FT	95.60
FIBERBOARD, 1" THICK	8.50 SQ FT	12.75
FIBERBOARD, 1/2" THICK	AS REQD	NIL
HONEYCOMB CELL	6 REQD	NIL
STEEL STRAPPING, 1-1/4"	85 FT	12.14
SEAL FOR 1-1/4" STRAPPING	10 REQD	NIL

CHAPTER 5

HIGHWAY TRANSPORTABILITY GUIDANCE

5-1. Scope

This chapter provides highway transportability guidance for movement of the STINGER weapon system. It covers technical and physical characteristics and safety considerations and prescribes the materials and guidance required to prepare, load, secure, and unload the vehicle.

5-2. Safety

In addition to the safety precautions contained in chapter 3, movement is subject to all the safety laws, rules, and regulations applicable to commercial carriers. In overseas areas, such movements are governed by theater regulations.

5-3. General

Highway transport of STINGER weapon system

weapon rounds or missile rounds shall be in accordance with security requirements of DOD 5100.76-M. Shipments will be made in trucks and semitrailers that offer van bodies or compartments that can be locked and sealed for exclusive use. Containers or CONEX, if used, must also be locked and sealed. Materials for loading, blocking, and bracing of trucks, semitrailers, and containers are shown in figure 5-1 at the end of this chapter.

NOTE

Figure 5-1 is extracted from US Army Development and Research Command missile drawing number 5947 GM 11SR1. Complete drawing, pages 1 through 56, may be obtained from US Army Defense Ammunition Center and School (SARAC-DEV) Savanna, IL 61074.

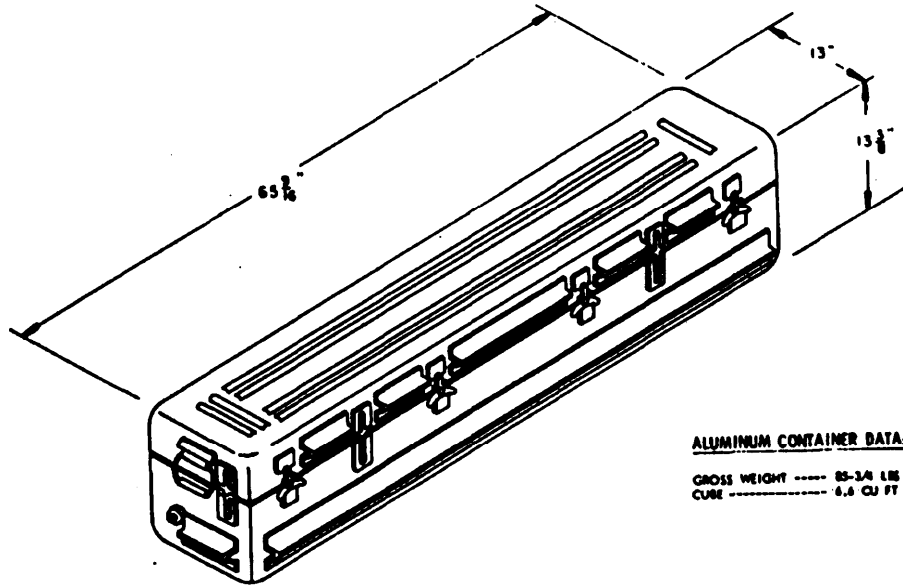

ALUMINUM CONTAINER DATA:

GROSS WEIGHT ----- 85-24 LBS (APPROX)
 CUBE ----- 6.6 CU FT (APPROX)

ALUMINUM CONTAINER

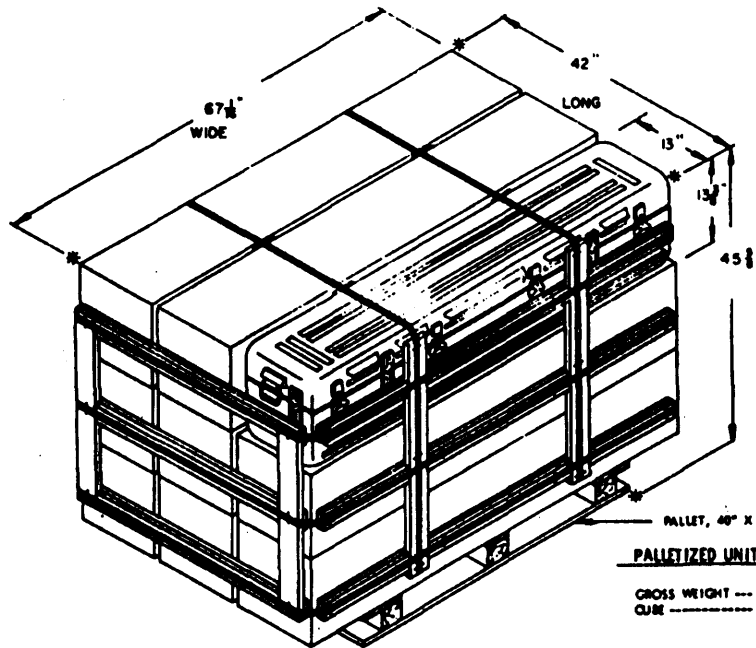

PALLET, 40" X 48", 4-WAY ENTRY.

PALLETIZED UNIT DATA:

GROSS WEIGHT --- 913 LBS (APPROX)
 CUBE ----- 73.81 CU FT (APPROX)

**PALLETIZED UNIT OF NINE (9) GUIDED MISSILES.
 PACKED ONE (1) PER ALUMINUM CONTAINER.**

Figure 5-1. Loading and bracing (TL and LTL) of the complete STINGER round in closed-or open-top van trailers, packed in wirebound and/or aluminum container (unitized and ununitized or palletized and unpalletized) (sheets 1 through 14).

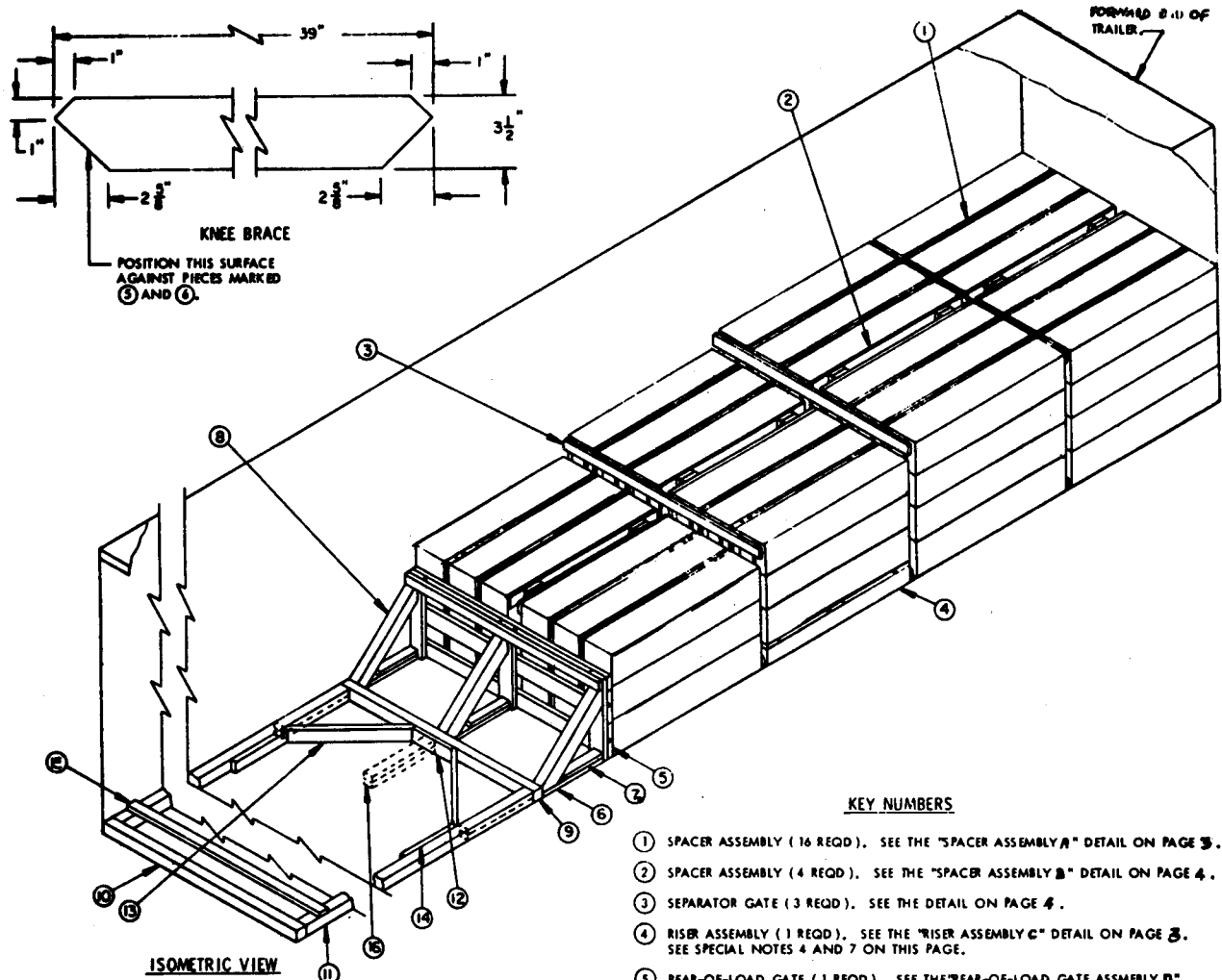

ISOMETRIC VIEW

SPECIAL NOTES:

1. THESE LTL OUTLOADING PROCEDURES ARE SHOWN DEPICTING THE USE OF "KNEE-BRACE" BLOCKING IN A 7'-6" WIDE TRAILER. WIDER OR NARROWER TRAILERS CAN BE USED.
2. THE "K-BRACE" BLOCKING, SHOWN AS PIECES MARKED ⑩ THROUGH ⑬ IS ADEQUATE FOR RETAINING NOT MORE THAN 18,000 POUNDS OF LADING.
3. PIECES MARKED ⑭ ARE FOR USE IN A TRAILER WHICH HAS A NAILABLE FLOOR AND SHOULD BE USED, IF POSSIBLE, IN LIEU OF PIECES MARKED ⑩ THROUGH ⑬ WHICH APPLY TO TRAILERS HAVING NON-NAILABLE FLOORS. THREE (3) BACK-UP CLEATS, SHOWN AS PIECES MARKED ⑮, ARE ADEQUATE FOR RETAINING A MAXIMUM SIZE LTL LOAD OF 15,000 POUNDS.
4. ONE OR MORE FILLER ASSEMBLIES, SHOWN AS PIECE MARKED ⑥ ON PAGE 5, MAY BE USED IN PLACE OF OMITTED CONTAINERS IN THE TOP LAYER ONLY. A RISER, PIECE MARKED ④, MUST BE USED WHEN LONGITUDINALLY ADJACENT STACKS ARE STEPPED UP OR DOWN.
5. IF THE TRAILER BEING LOADED HAS A ROUND-FRONT OR ROUNDED CORNERS AT THE FORWARD END, REFER TO PAGE 6 FOR "FORWARD BLOCKING" SPECIFICATIONS WHICH MUST BE USED.
6. IF THE TRAILER BEING UNLOADED CONTAINS MECHANICAL BRACING DEVICES THEY MAY BE USED IN LIEU OF PIECES MARKED ⑥ THRU ⑮. POSITION THE CROSS MEMBERS AT THE 4", 16" AND 28" HEIGHT DIMENSIONS FOR THE LOAD SHOWN ABOVE. INSTALL CROSS MEMBERS TIGHTLY AGAINST THE REAR-OF-LOAD GATE.
7. THE USE OF A RISER ASSEMBLY IS SPECIFIED FOR THE DEPICTED LOAD ONLY TO SHOW A TYPICAL APPLICATION. RISER ASSEMBLIES MAY BE USED IN THE LOAD AS REQUIRED TO ADJUST THE LOADING PATTERN FOR THE NUMBER OF CONTAINERS TO BE SHIPPED.

KEY NUMBERS

- ① SPACER ASSEMBLY (16 REQD). SEE THE "SPACER ASSEMBLY A" DETAIL ON PAGE 3 .
- ② SPACER ASSEMBLY (4 REQD). SEE THE "SPACER ASSEMBLY B" DETAIL ON PAGE 4 .
- ③ SEPARATOR GATE (3 REQD). SEE THE DETAIL ON PAGE 4 .
- ④ RISER ASSEMBLY (1 REQD). SEE THE "RISER ASSEMBLY C" DETAIL ON PAGE 3 . SEE SPECIAL NOTES 4 AND 7 ON THIS PAGE.
- ⑤ REAR-OF-LOAD GATE (1 REQD). SEE THE "REAR-OF-LOAD GATE ASSEMBLY D" DETAIL ON PAGE 5 .
- ⑥ FLOOR CLEAT, 2" X 4" BY CUT-TO-FIT (27-1/2" REF) (3 REQD).
- ⑦ POCKET CLEAT, 2" X 4" X 18" (3 REQD). NAIL TO FLOOR CLEAT MARKED ⑥ W/5-10d NAILS. TOENAIL TO THE VERTICAL PIECE ON REAR-OF-LOAD GATE, PIECE MARKED ⑤, W/2-12d NAILS AT EACH JOINT.
- ⑧ KNEE BRACE, 4" X 4" X 39" (3 REQD). SEE THE "KNEE BRACE" DETAIL ABOVE FOR THE BEVEL CUTS REQUIRED. TOENAIL TO PIECES MARKED ⑤ AND ⑥ W/2-16d NAILS AT EACH END.
- ⑨ FORWARD HEADER, 4" X 4" BY TRAILER WIDTH MINUS 1/2" (1 REQD). TOENAIL TO PIECE MARKED ⑧ W/2-16d NAILS AT EACH JOINT.
- ⑩ REAR HEADER, 4" X 4" BY TRAILER WIDTH MINUS 1/2" (1 REQD). POSITION AGAINST REAR CORNER POSTS IF THE TRAILER IS SO EQUIPPED, OR POSITION TO CONTACT REAR DOORS OF THE TRAILER WHEN THEY ARE CLOSED. SEE SPECIAL NOTE 2 ON THIS PAGE.
- ⑪ SIDE STRUT, 4" X 4" BY CUT-TO-FIT BETWEEN PIECES MARKED ⑧ AND ⑩ (2 REQD). TOENAIL TO PIECES MARKED ⑧ AND ⑩ W/2-16d NAILS AT EACH END.
- ⑫ CENTER CLEAT, 2" X 4" X 18" (1 REQD). NAIL TO PIECE MARKED ⑧ W/4-12d NAILS.
- ⑬ DIAGONAL BRACE, 2" X 4" BY CUT-TO-FIT (2 REQD). DOUBLE BEVEL EACH END WITH 45° CUTS. INSTALL AT A 45° ANGLE AS SHOWN AND TOENAIL TO PIECES MARKED ⑧ AND ⑪ W/2-16d NAILS AT EACH END.
- ⑭ BACK-UP CLEAT, 2" X 4" X 24" (2 REQD). NAIL TO PIECE MARKED ⑪ W/6-12d NAILS.
- ⑮ STRUT BRACING, 2" X 4" BY TRAILER WIDTH MINUS 1/2" (MINIMUM OF 1 REQD). INSTALL ONE (1) NEAR REAR END OF STRUTS MARKED ⑪ AS SHOWN. ONE (1) ADDITIONAL PIECE REQUIRED FOR EVERY 7'-0" OF STRUT LENGTH. NAIL TO PIECES MARKED ⑪ W/3-12d NAILS AT EACH END.
- ⑯ BACK-UP CLEAT, 2" X 4" X 30" (DOUBLED) (3 REQD). ALIGN WITH A KNEE BRACE MARKED ⑧ AND NAIL THE FIRST PIECE TO THE TRAILER FLOOR W/7-12d NAILS. NAIL THE SECOND TO THE FIRST IN A LIKE MANNER. SEE SPECIAL NOTE 3 ON THIS PAGE.

TYPICAL LTL - 84 UNPALLETIZED ALUMINUM CONTAINERS IN A CONVENTIONAL TYPE VAN TRAILER

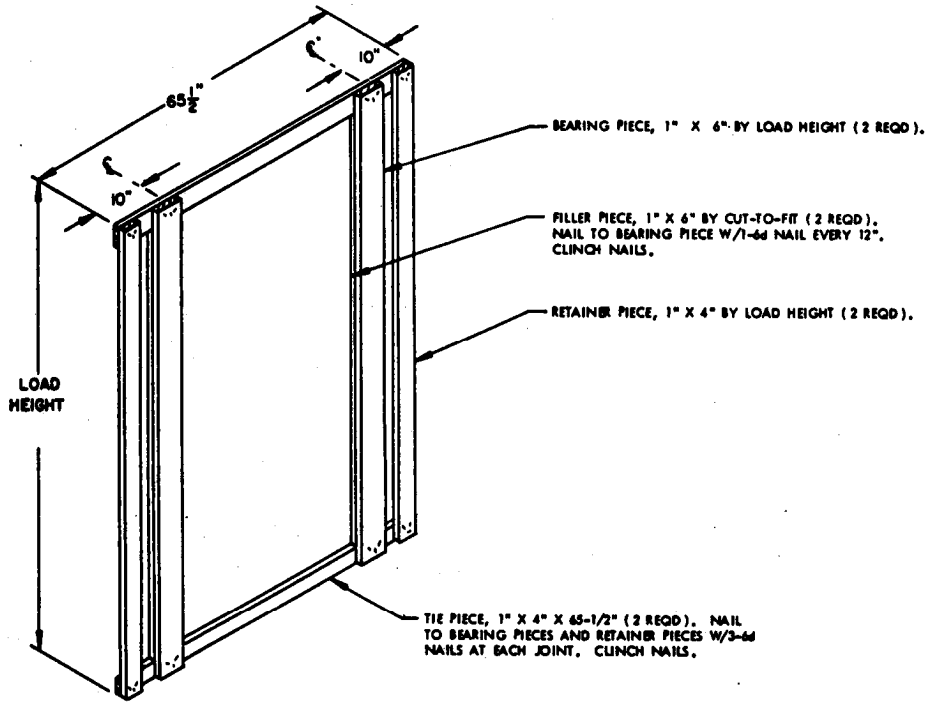

SPACER ASSEMBLY A

THIS SPACER ASSEMBLY IS DESIGNED FOR USE IN LOADS OF UNPALLETIZED ALUMINUM CONTAINERS.

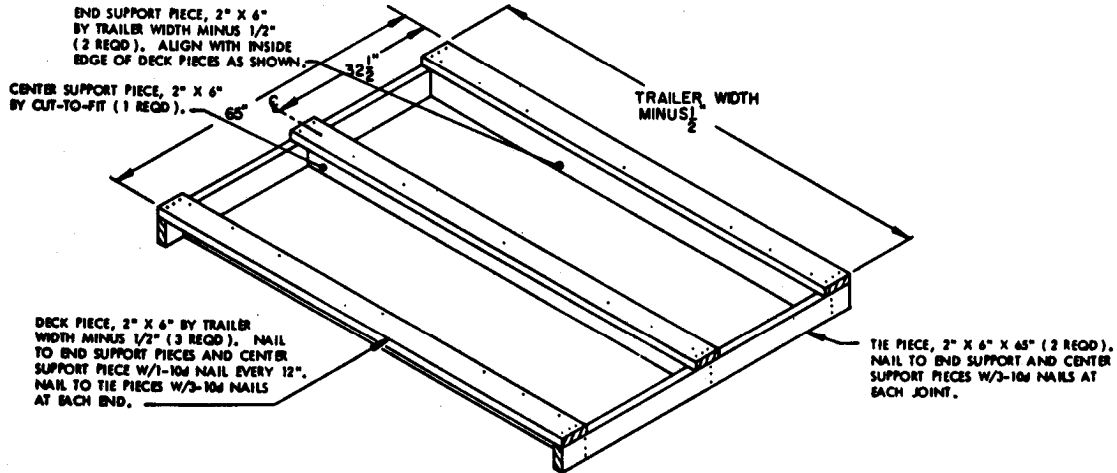

RISER ASSEMBLY

THIS RISER ASSEMBLY IS DESIGNED FOR USE IN LOADS OF UNPALLETIZED ALUMINUM CONTAINERS.

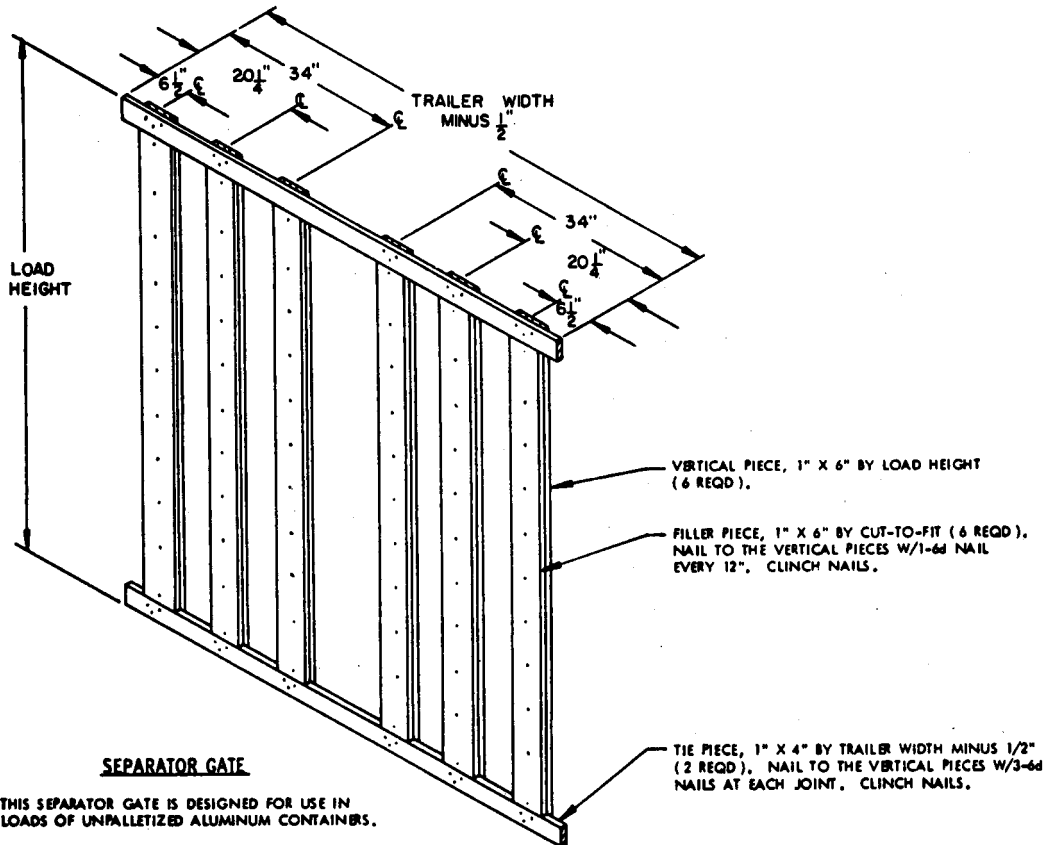
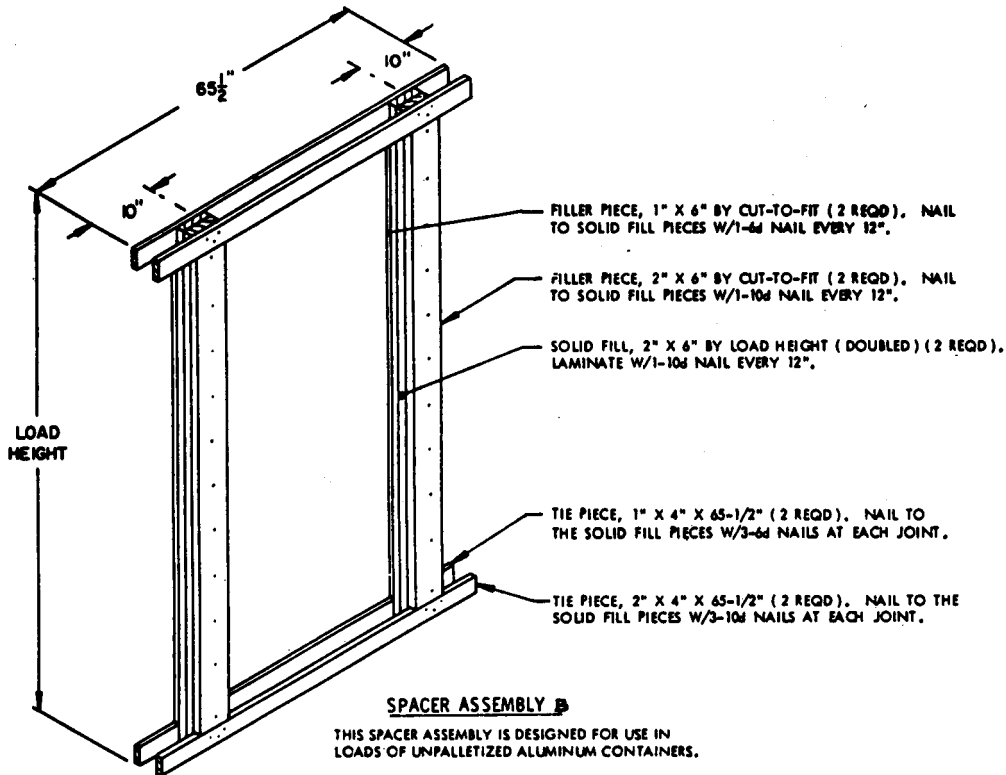

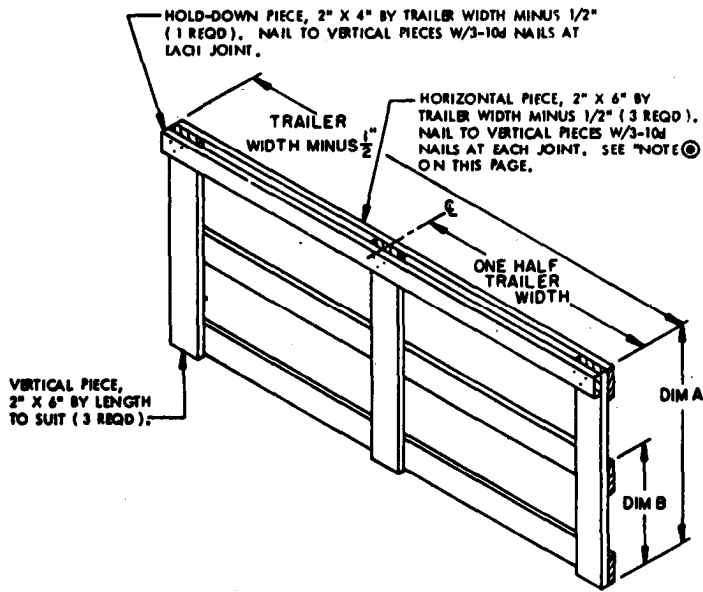

REAR OF LOAD GATE (D)

THIS GATE IS DESIGNED FOR USE AT THE REAR END OF A THREE (3) LAYER LOAD OF UNINITIALIZED WIREBOUND CONTAINERS OR UNPALLETIZED ALUMINUM CONTAINERS AS DEPICTED ON PAGES AND . NOTE: THIS TYPE OF GATE CAN ONLY BE USED AGAINST THE REAR OF A TWO OR THREE LAYER UNPALLETIZED LOAD. SEE "CHART A" ON THIS PAGE FOR GUIDANCE IN FABRICATING GATES.

CHART A		
THREE (3) LAYER LOAD	DIM A	DIM B
WIREBOUND CONTAINERS	31-1/2"	19"
ALUMINUM CONTAINERS	33-1/2"	20-1/2"
TWO (2) LAYER LOAD	DIM A	DIM B
WIREBOUND CONTAINERS	21"	*
ALUMINUM CONTAINERS	20-1/2"	*

* HORIZONTAL PIECE NOT REQUIRED AT THIS LOCATION.

NOTE (C):

IF DESIRED 1/2" PLYWOOD MAY BE USED IN LIEU OF THE 2" X 6" HORIZONTAL PIECES. THE PLYWOOD MUST BE TRAILER WIDTH MINUS 1/2" BY LOAD HEIGHT. SECURE THE PLYWOOD TO THE VERTICAL PIECES W/1-6d NAIL EVERY 12". ALL PLYWOOD JOINTS MUST CENTER ON THE MIDDLE VERTICAL PIECE.

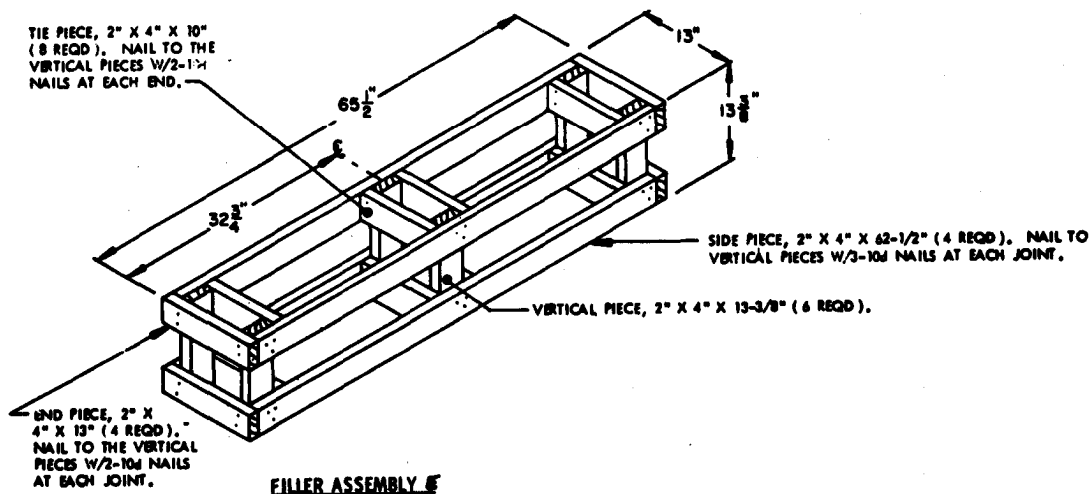

FILLER ASSEMBLY (E)

THE FILLER ASSEMBLY SHOWN ABOVE IS TO BE USED WITHIN LOADS TO TAKE THE PLACE OF AN OMITTED ALUMINUM CONTAINER. IT MUST BE USED IN THE TOP LAYER ONLY.

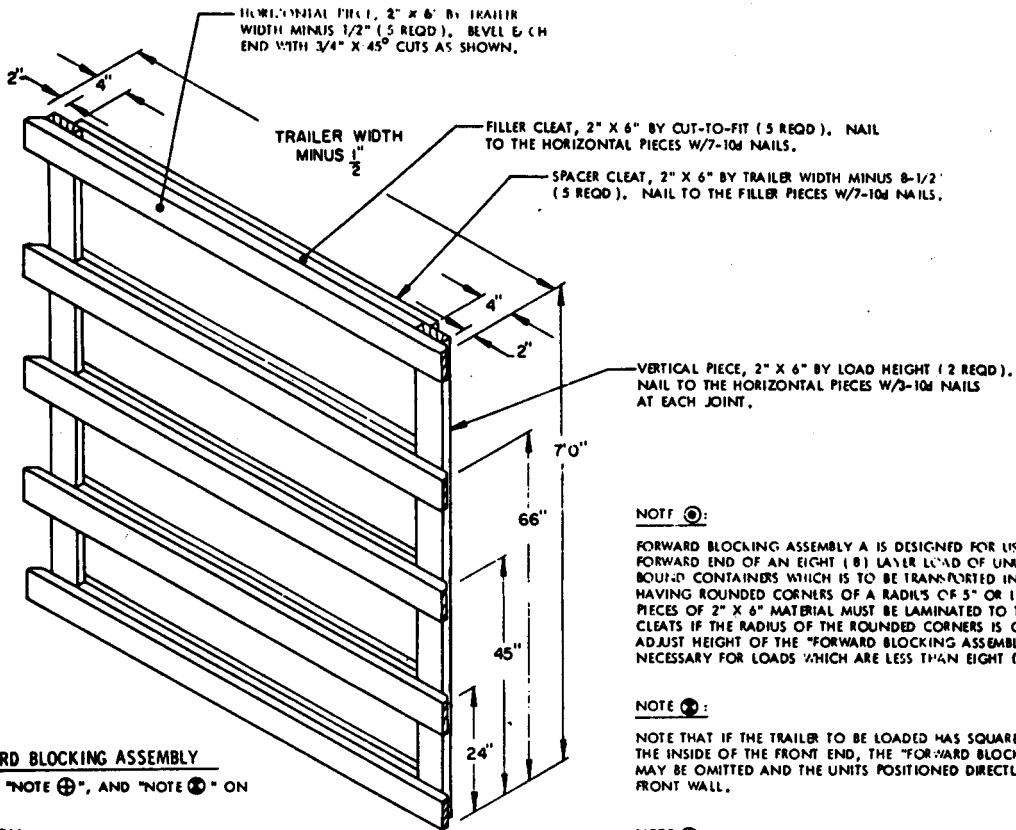

FORWARD BLOCKING ASSEMBLY
SEE "NOTE ①", "NOTE ②", AND "NOTE ③" ON THIS PAGE.

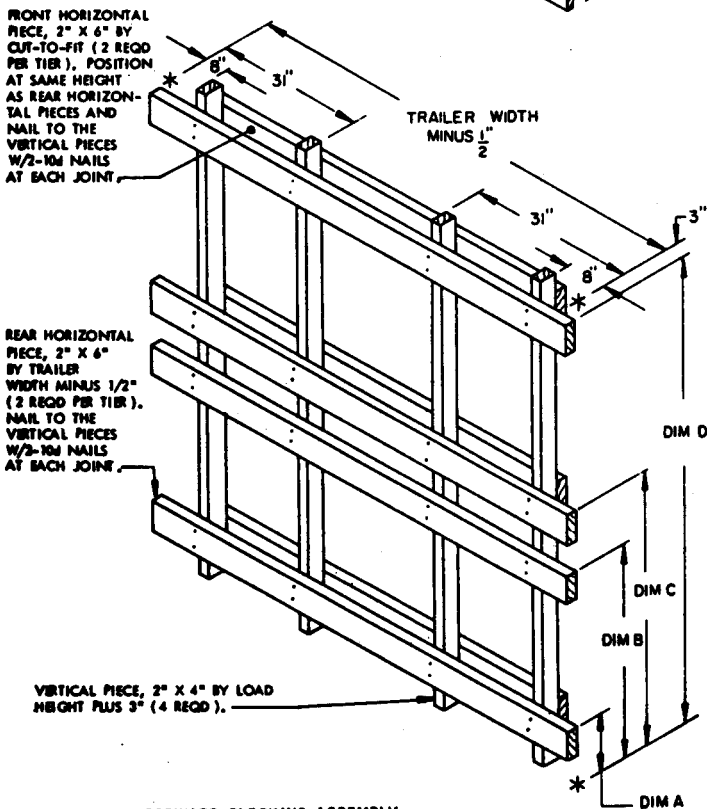

FORWARD BLOCKING ASSEMBLY
SEE "NOTE ④", "NOTE ⑤", "NOTE ⑥" AND "CHART B" ON THIS PAGE.

NOTE ①:

FORWARD BLOCKING ASSEMBLY A IS DESIGNED FOR USE AT THE FORWARD END OF AN EIGHT (8) LAYER LOAD OF UNINITIALIZED WIRE BOUND CONTAINERS WHICH IS TO BE TRANSPORTED IN A TRAILER HAVING ROUNDED CORNERS OF A RADIUS OF 5" OR LESS. ADDITIONAL PIECES OF 2" X 6" MATERIAL MUST BE LAMINATED TO THE SPACER CLEATS IF THE RADIUS OF THE ROUNDED CORNERS IS GREATER THAN 5". ADJUST HEIGHT OF THE "FORWARD BLOCKING ASSEMBLY A" AS NECESSARY FOR LOADS WHICH ARE LESS THAN EIGHT (8) LAYERS HIGH.

NOTE ②:

NOTE THAT IF THE TRAILER TO BE LOADED HAS SQUARE CORNERS ON THE INSIDE OF THE FRONT END, THE "FORWARD BLOCKING ASSEMBLY" MAY BE OMITTED AND THE UNITS POSITIONED DIRECTLY AGAINST THE FRONT WALL.

NOTE ③:

IF DESIRED 1/2" PLYWOOD MAY BE USED IN LIEU OF THE 2" X 4" HORIZONTAL PIECES. THE PLYWOOD MUST BE TRAILER WIDTH MINUS 1/2" BY LOAD HEIGHT. SECURE THE PLYWOOD TO THE VERTICAL W/3-10# NAIL EVERY 12".

NOTE ④:

FORWARD BLOCKING ASSEMBLY B IS DESIGNED FOR USE AT THE FORWARD END OF A 1-TIER OR 2-TIER LOAD OF PALLETIZED ALUMINUM CONTAINERS OR SKIDDED UNITS OF WIREBOUND CONTAINERS WHICH IS TO BE TRANSPORTED IN A TRAILER HAVING ROUNDED CORNERS OF A RADIUS OF 6" OR LESS. IF THE TRAILER HAS ROUNDED CORNERS WITH A RADIUS GREATER THAN 6", THE VERTICAL PIECES MUST BE 2" X 4" MATERIAL IN LIEU OF 2" X 4" MATERIAL.

CHART B				
	DIM A	DIM B	DIM C	DIM D
ALUMINUM CONTAINERS	12"	38"	58"	84"
WIREBOUND CONTAINERS	11-1/2"	36"	48"	72"

DETAILS

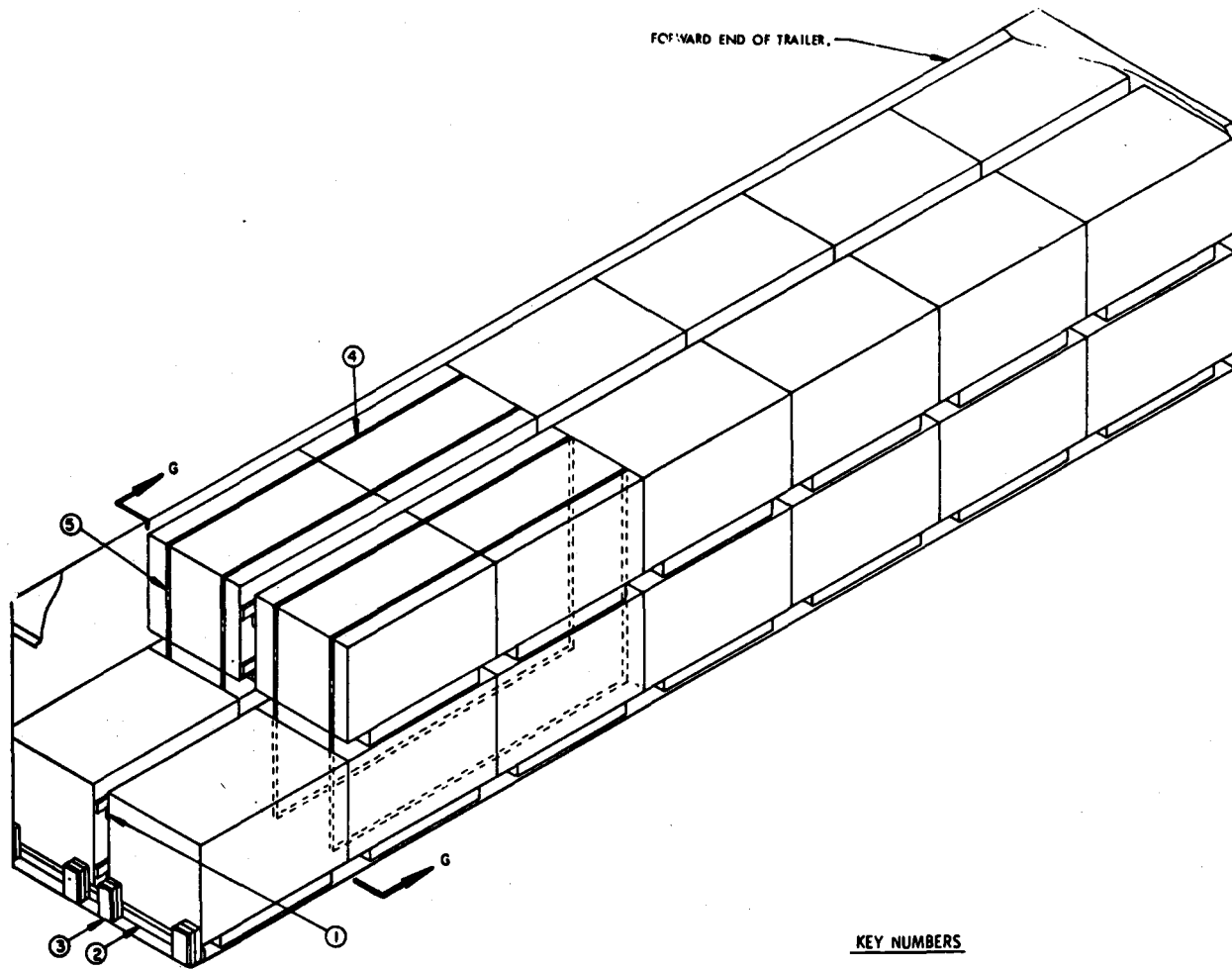

ISOMETRIC VIEW

KEY NUMBERS

- ① ANTI-SWAY BRACE ASSEMBLY (7 REQD.). SEE THE "ANTI-SWAY BRACE ASSEMBLY" DETAIL ON PAGE 9. INSTALL BETWEEN LATERALLY ADJACENT ROWS OF PALLETIZED UNITS. SEE SPECIAL NOTES 2 AND 3 ON PAGE 8.
- ② TIE PIECE, 2" X 4" BY TRAILER WIDTH MINUS 1/2" IN LENGTH. SEE SPECIAL NOTE 4 ON PAGE 8.
- ③ SOLID FILL, 6" WIDE MATERIAL BY 12" LONG BY THICKNESS TO SUIT (AS REQD.). NAIL FIRST PIECE TO PIECE MARKED ② W/3-10d NAILS. NAIL EACH ADDITIONAL PIECE TO THE FIRST PIECE W/3-10d NAILS. SEE SPECIAL NOTE 4 ON PAGE 8.
- ④ BUNDLING STRAP, 1-1/4" X .035" X 38'-6" LONG STEEL STRAPPING (4 REQD.). PREPOSITION AND INSTALL SO AS TO ENCIRCLE TWO (2) PALLETIZED UNIT STACKS AS SHOWN.
- ⑤ SEAL FOR 1-1/4" STRAPPING (8 REQD., 2 PER STRAP). DOUBLE CRIMP EACH SEAL.

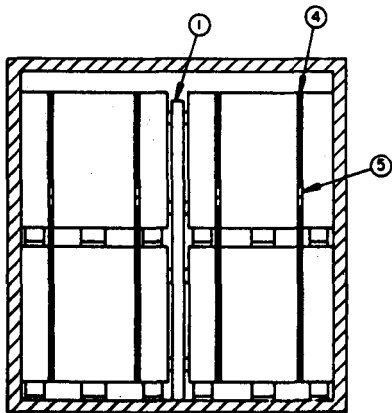

SECTION G-G

26 PALLETIZED UNITS OF ALUMINUM CONTAINERS IN A 40'-0" LONG CONVENTIONAL TYPE VAN TRAILER

SPECIAL NOTES:

1. A LOAD OF 26 PALLETIZED UNITS IS SHOWN IN A 40'-0" LONG BY 7'-6" WIDE (INSIDE DIMENSION) CONVENTIONAL TYPE VAN TRAILER.
2. A WIDER OR NARROWER TRAILER THAN SHOWN MAY BE USED FOR SHIPPING THE DEPICTED LOAD. ADJUST THE WIDTH OF THE "ANTI-SWAY BRACE ASSEMBLY" AS NECESSARY.
3. THE ANTI-SWAY BRACING MAY BE OMITTED IF THE SPACE BETWEEN LATRALLY ADJACENT UNITS IS 5" OR LESS, AS MEASURED FROM CONTAINER TO CONTAINER ON LATRALLY ADJACENT UNITS.
4. IF THE VOID AT THE REAR OF THE LOAD, BETWEEN THE PALLETIZED CONTAINERS AND THE REAR DOORS, MEASURES 1-1/2" OR LESS, NO REAR BLOCKING IS REQUIRED. IF THE VOID AT THE REAR OF THE LOAD IS GREATER THAN 1-1/2" BUT LESS THAN 12" ADDITIONAL FILL PIECES OF 4" WIDE MATERIAL MUST BE LAMINATED TO PIECES MARKED ④. IF THE VOID AT THE REAR OF THE LOAD EXCEEDS 12", USE REAR BLOCKING AS SHOWN ON PAGE 9.
5. TO SATISFY THE QUANTITY OF PALLETIZED UNITS TO BE SHIPPED, THE LOAD AS SHOWN MAY BE DECREASED BY OMITTING TWO (2) ADJACENT PALLETIZED UNITS AT A TIME. TWO ADDITIONAL PALLET UNITS CAN BE LOADED IF DOOR HEIGHT PERMITS.
6. IF THE TRAILER BEING LOADED HAS A ROUND-FRONT OR ROUNDED CORNERS AT THE FORWARD END, REFER TO PAGE 6 FOR "FORWARD BLOCKING" SPECIFICATIONS WHICH MUST BE USED.
7. IF THE TRAILER BEING OUTLOADED CONTAINS MECHANICAL BRACING DEVICES, SUCH AS A WALL BELT RAIL AND LOAD BLOCKING CROSS MEMBERS, WHICH CONFORM TO SPECIFICATIONS SET FORTH WITHIN THE BUREAU OF EXPLOSIVES PAMPHLET 6C AND APPENDICES THEREOF, THEY MAY BE USED AT THE REAR OF THE LOAD AS SHOWN IN THE "PARTIAL ELEVATION VIEW" ON THIS PAGE. THE MECHANICAL BRACING DEVICE SYSTEM OF A TRAILER MUST HAVE A LENGTH OF AT LEAST 39'-6" AS MEASURED FROM THE FRONT WALL OF THE TRAILER.

BILL OF MATERIAL		
LUMBER	LINEAR FEET	BOARD FEET
2" X 4"	393	262
1" X 6"	4	2
2" X 6"	8	8
NAILS	NO. REQD	POUNDS
10d (3")	240	3-3/4
STEEL STRAPPING, 1-1/4" X .035" ----- 154' REQD		22 LBS
SBL FOR 1-1/4" STRAPPING ----- 8 REQD		NIL

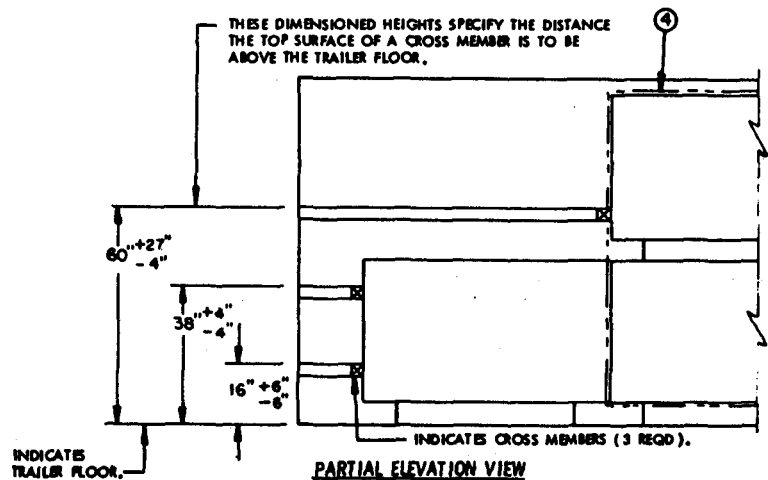

THE VIEW SHOWN ABOVE INDICATES THE REAR OF THE LOAD SHOWN ON PAGE 7. SEE SPECIAL NOTE 7 ON THIS PAGE.

LOAD AS SHOWN

ITEM	QUANTITY	WEIGHT (APPROX)
PALLETIZED UNIT -----	26 -----	24,518 LBS
DUNNAGE -----	-----	570 LBS
TOTAL WEIGHT -----		25,088 LBS

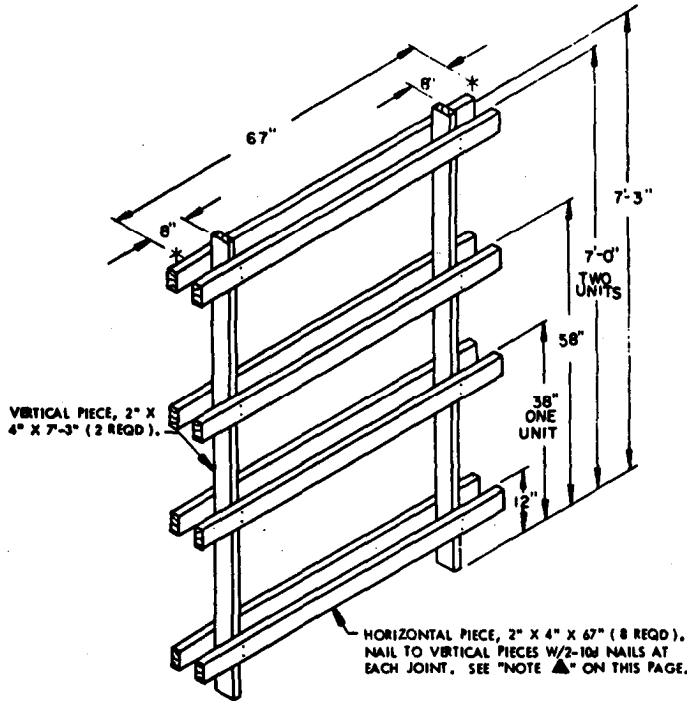

ANTI-SWAY BRACE ASSEMBLY F

THIS ANTI-SWAY BRACE IS DESIGNED FOR USE BETWEEN 1-TIER OR 2-TIER LOADS OF PALLETIZED ALUMINUM CONTAINERS.

NOTE ▲:

IF THE VOID SPACE BETWEEN LATERALLY ADJACENT PALLETIZED UNITS IS GREATER THAN 7-1/2", ADDITIONAL PIECES OF 4" WIDE MATERIAL BY THICKNESS-TO-SUIT, MAY BE LAMINATED TO THE HORIZONTAL PIECES. IF THE VOID SPACE IS LESS THAN 6-1/2" 1" X 4" MATERIAL MAY BE USED FOR THE HORIZONTAL PIECES IN LIEU OF 2" X 4" MATERIAL.

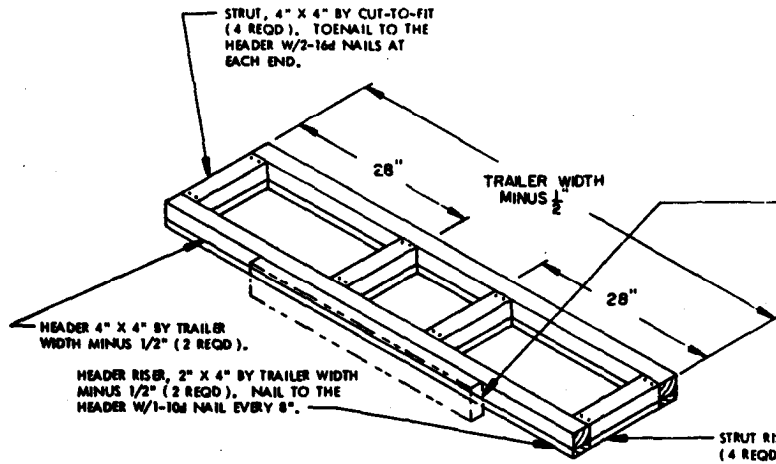

REAR BLOCKING ASSEMBLY

THIS REAR BLOCKING ASSEMBLY IS DESIGNED FOR USE AT THE REAR END OF A LOAD OF PALLETIZED ALUMINUM CONTAINERS WHEN THE DISTANCE BETWEEN THE REAR OF THE LOAD AND THE REAR DOORS WHEN THEY ARE CLOSED MEASURES 12" OR MORE. CAUTION: STRUTS LONGER THAN 7'-0" WILL NOT BE USED; USE A "X-BRACE" TYPE OF REAR BLOCKING AS DEPICTED ON PAGE 36 TO FACILITATE COMPLIANCE WITH THIS RULE. IF 4" X 4" MATERIAL IS NOT AVAILABLE, SEE THE "ALTERNATIVE REAR BLOCKING" DETAIL AT THE RIGHT.

IF THE TRAILER IS EQUIPPED WITH REAR CORNER POSTS, INSTALL SOLID FILL 6" WIDE BY 48" LONG BY THE THICKNESS REQUIRED TO FILL THE EXCESS SPACE BETWEEN THE REAR BLOCKING ASSEMBLY AND THE TRAILER DOORS WHEN THEY ARE CLOSED. NAIL TO THE REAR BLOCKING ASSEMBLY W/4-10d NAILS.

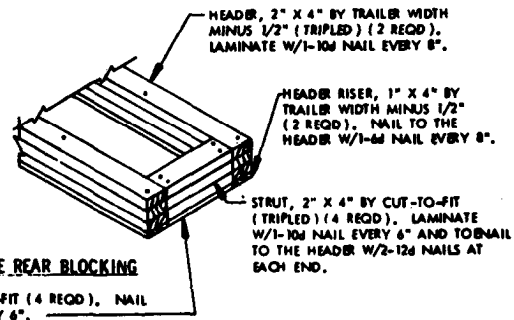

ALTERNATIVE REAR BLOCKING

STRUT RISER, 1" X 4" BY CUT-TO-FIT (4 REQD.), NAIL TO THE STRUT W/1-6d NAIL EVERY 6".

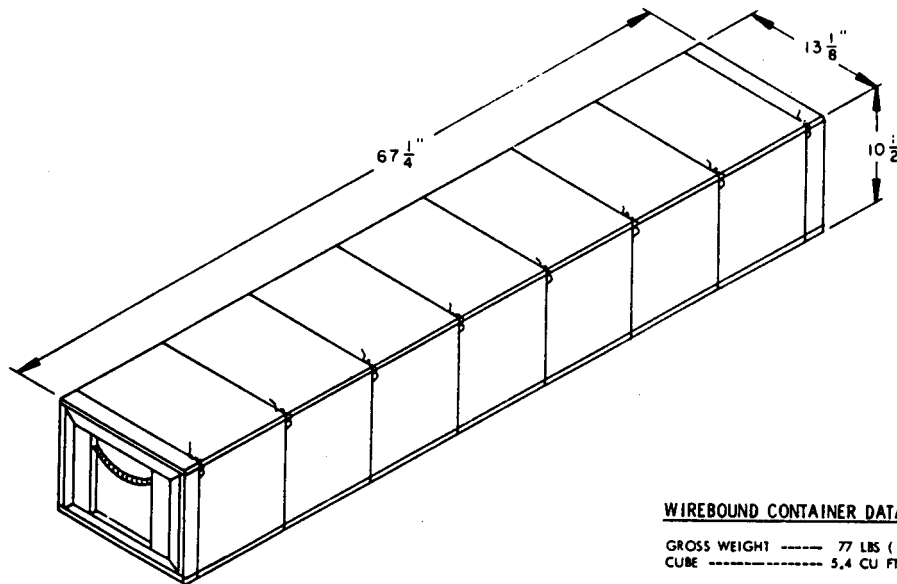

WIREBOUND CONTAINER DATA:

GROSS WEIGHT ----- 77 LBS (APPROX)
 CUBE ----- 5.4 CU FT (APPROX)

WIREBOUND CONTAINER

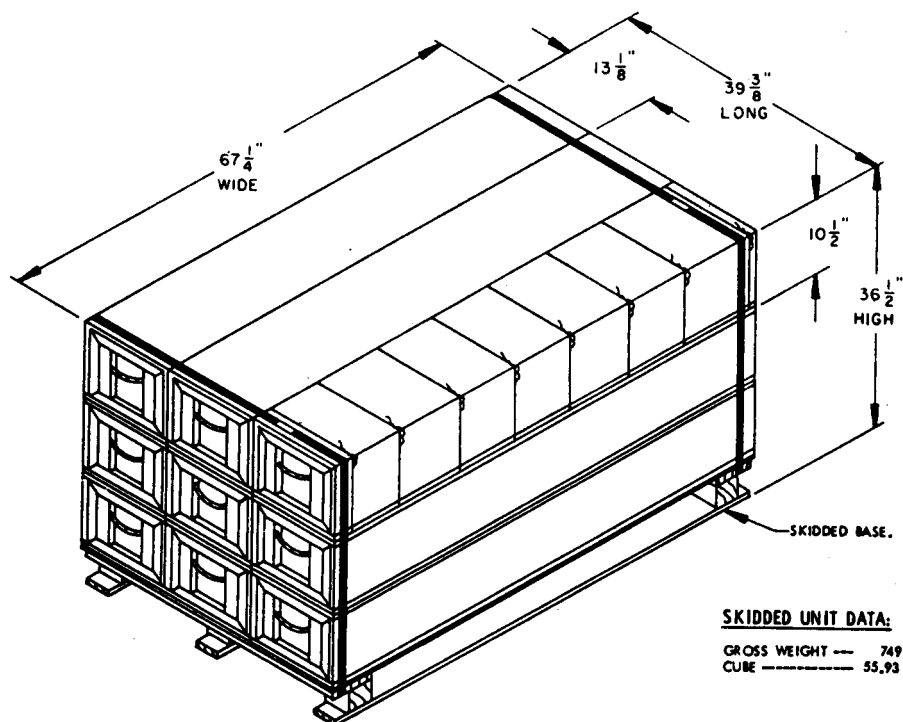

SKIDDED UNIT DATA:

GROSS WEIGHT --- 749 LBS (APPROX)
 CUBE ----- 55.93 CU FT (APPROX)

**SKIDDED UNIT OF NINE (9) GUIDED MISSILES,
 PACKED ONE (1) PER WIREBOUND (WOODEN) BOX**

BILL OF MATERIAL		
LUMBER	LINEAR FEET	BOARD FEET
2" X 4"	196	131
2" X 6"	54	54
NAILS	NO. REQD	POUNDS
10d	208	3-1/4

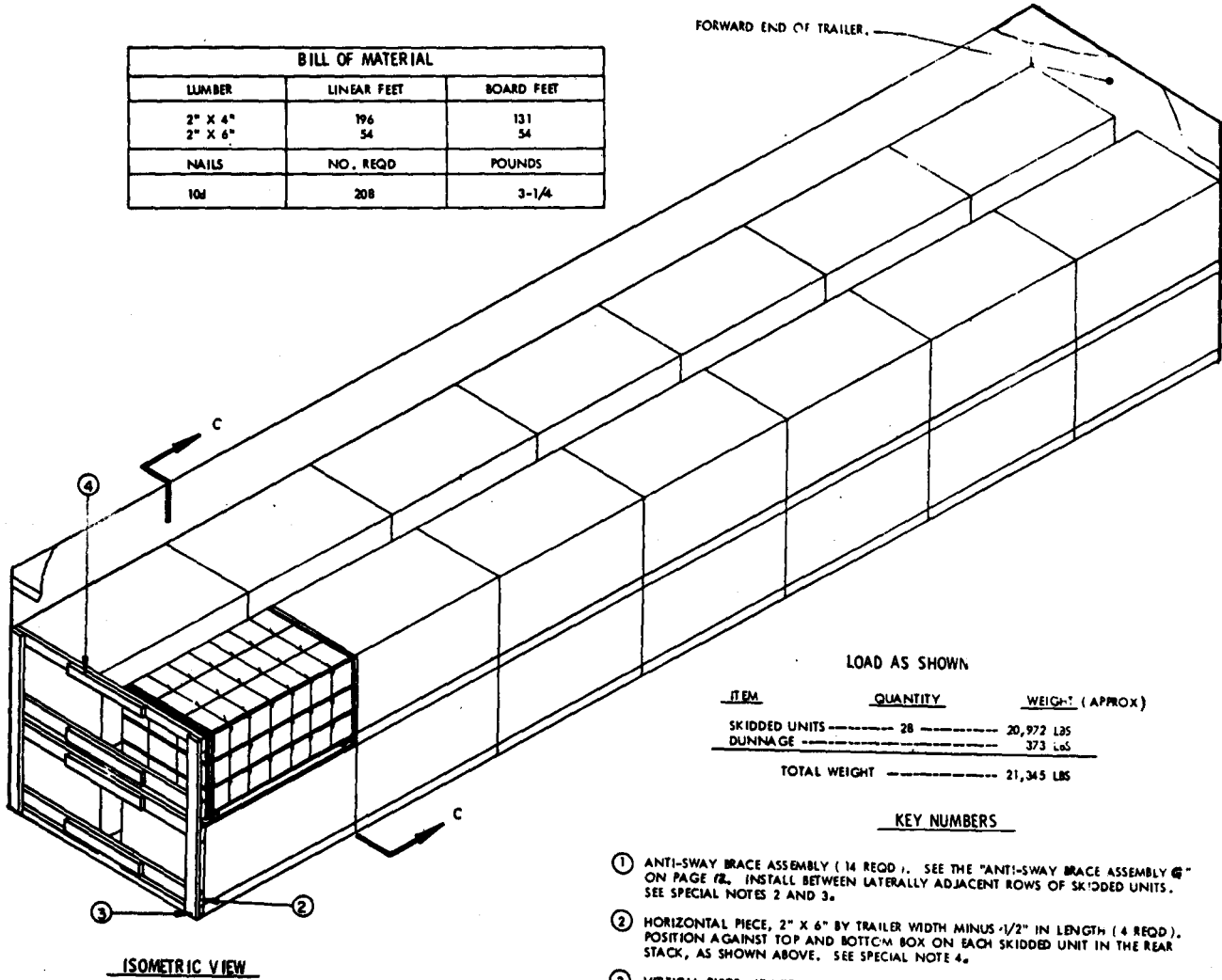

ISOMETRIC VIEW

LOAD AS SHOWN

ITEM	QUANTITY	WEIGHT (APPROX)
SKIDDED UNITS	28	20,972 LBS
DUNNAGE		373 LBS
TOTAL WEIGHT		21,345 LBS

KEY NUMBERS

- ① ANTI-SWAY BRACE ASSEMBLY (14 REQD.). SEE THE "ANTI-SWAY BRACE ASSEMBLY" ON PAGE 72. INSTALL BETWEEN LATERALLY ADJACENT ROWS OF SKIDDED UNITS. SEE SPECIAL NOTES 2 AND 3.
- ② HORIZONTAL PIECE, 2" X 6" BY TRAILER WIDTH MINUS 1/2" IN LENGTH (4 REQD.). POSITION AGAINST TOP AND BOTTOM BOX ON EACH SKIDDED UNIT IN THE REAR STACK, AS SHOWN ABOVE. SEE SPECIAL NOTE 4.
- ③ VERTICAL PIECE, 6" WIDE MATERIAL BY THICKNESS-TO-SUIT BY LOAD HEIGHT (2 REQD.). NAIL TO HORIZONTAL PIECE W/3-APPROPRIATELY SIZED NAILS AT EACH JOINT. SEE SPECIAL NOTE 4.
- ④ SOLID FILL, 6" WIDE MATERIAL BY THICKNESS-TO-SUIT (4 REQD.). NAIL TO HORIZONTAL PIECES W/4-APPROPRIATELY SIZED NAILS IN EACH PIECE. SEE SPECIAL NOTE 4.

SPECIAL NOTES:

1. A LOAD OF 28 SKIDDED UNITS IS SHOWN IN A 40'-0" LONG BY 7'-6" WIDE (INSIDE DIMENSION) CONVENTIONAL TYPE VAN TRAILER.
2. A WIDER OR NARROWER TRAILER THAN SHOWN MAY BE USED FOR SHIPPING THE DEPICTED LOAD. ADJUST THE WIDTH OF THE "ANTI-SWAY BRACE ASSEMBLY A" AS NECESSARY.
3. THE ANTI-SWAY BRACING MAY BE OMITTED IF THE SPACE BETWEEN LATERALLY ADJACENT UNITS IS 5" OR LESS, AS MEASURED FROM CONTAINER TO CONTAINER ON LATERALLY ADJACENT UNITS.
4. IF THE VOID AT THE REAR OF THE LOAD, BETWEEN THE SKIDDED UNITS AND THE REAR DOORS, MEASURES 1-1/2" OR LESS, NO REAR BLOCKING IS REQUIRED. IF THE VOID AT THE REAR OF THE LOAD IS GREATER THAN 1-1/2" BUT LESS THAN 12", ADDITIONAL FILL PIECES OF 6" WIDE MATERIAL MUST BE LAMINATED TO PIECES MARKED ③ AND PIECES MARKED ④ WITH APPROPRIATELY SIZED NAILS.

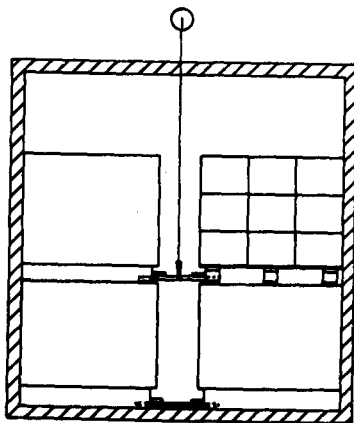

SECTION C-C

28 SKIDDED UNITS OF WIREBOUND CONTAINERS IN A 40'-0" LONG CONVENTIONAL TYPE VAN TRAILER

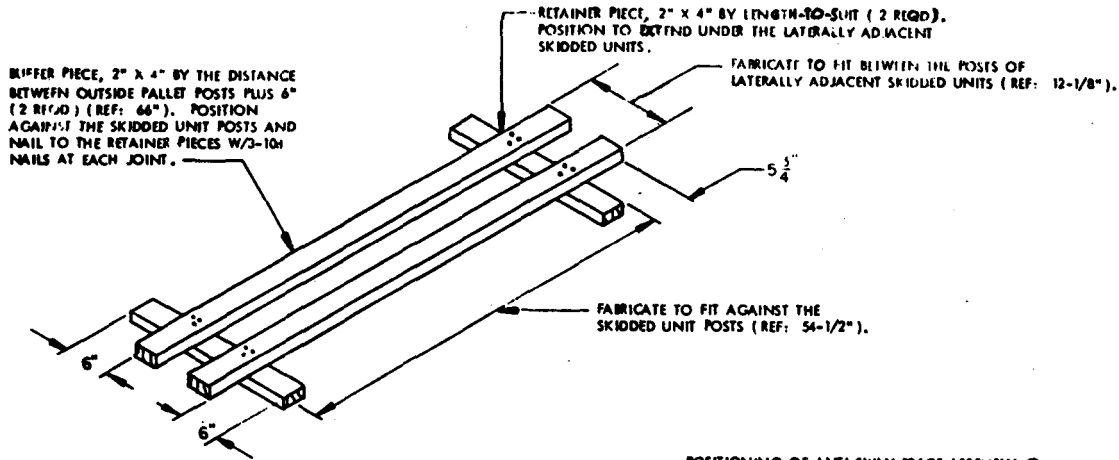

ANTI-SWAY BRACE ASSEMBLY G

THIS ANTI-SWAY BRACE IS DESIGNED FOR USE BETWEEN 1-TIER OR 2-TIER LOADS OF UNITIZED WIREBOUND CONTAINERS (SKIDDED UNITS). SEE THE "POSITIONING OF ANTI-SWAY BRACE ASSEMBLY G" ON THIS PAGE.

POSITIONING OF ANTI-SWAY BRACE ASSEMBLY G

1. THE "ANTI-SWAY BRACE ASSEMBLY G" MUST BE FABRICATED IN PLACE BETWEEN LATERALLY ADJACENT SKIDDED UNITS.
 - A. POSITION THE FIRST RETAINER PIECE JUST BEHIND THE NEAR POSTS ON LATERALLY ADJACENT SKIDDED UNITS, SPANNING THE VOID BETWEEN THEM AND RESTING ON THE BOTTOM BOARDS OF THE SKIDDED UNITS.
 - B. POSITION A 2" X 4" X 66" BUFFER PIECE 6" FROM THE END OF THE FIRST RETAINER PIECE AND EXTENDING 5-3/4" BEYOND THE EDGE OF THE FIRST RETAINER PIECE. NAIL THE BUFFER PIECE TO THE RETAINER PIECE W/3-10d NAILS.
 - C. KEEPING THE FIRST BUFFER PIECE AGAINST THE SIDE OF A SKIDDED UNIT, POSITION THE SECOND BUFFER PIECE AGAINST THE SIDE OF THE LATERALLY ADJACENT SKIDDED UNIT AND EXTENDING 5-3/4" BEYOND THE EDGE OF THE FIRST RETAINER PIECE. NAIL THE BUFFER PIECE TO THE RETAINER PIECE W/3-10d NAILS.
 - D. HOLD THE ENDS OF BOTH BUFFER PIECES AND PUSH THE PARTIAL ASSEMBLY FORWARD UNTIL THE FIRST RETAINER PIECE CONTACTS THE SKIDDED UNIT POSTS ON THE FAR END.
 - E. POSITION THE SECOND RETAINER PIECE JUST BEHIND AND CONTACTING THE NEAR POSTS ON LATERALLY ADJACENT SKIDDED UNITS.
 - F. KEEP THE TWO BUFFER PIECES AGAINST THE SIDES OF THE LATERALLY ADJACENT SKIDDED UNITS AND NAIL EACH ONE TO THE SECOND RETAINER PIECE W/3-10d NAILS.

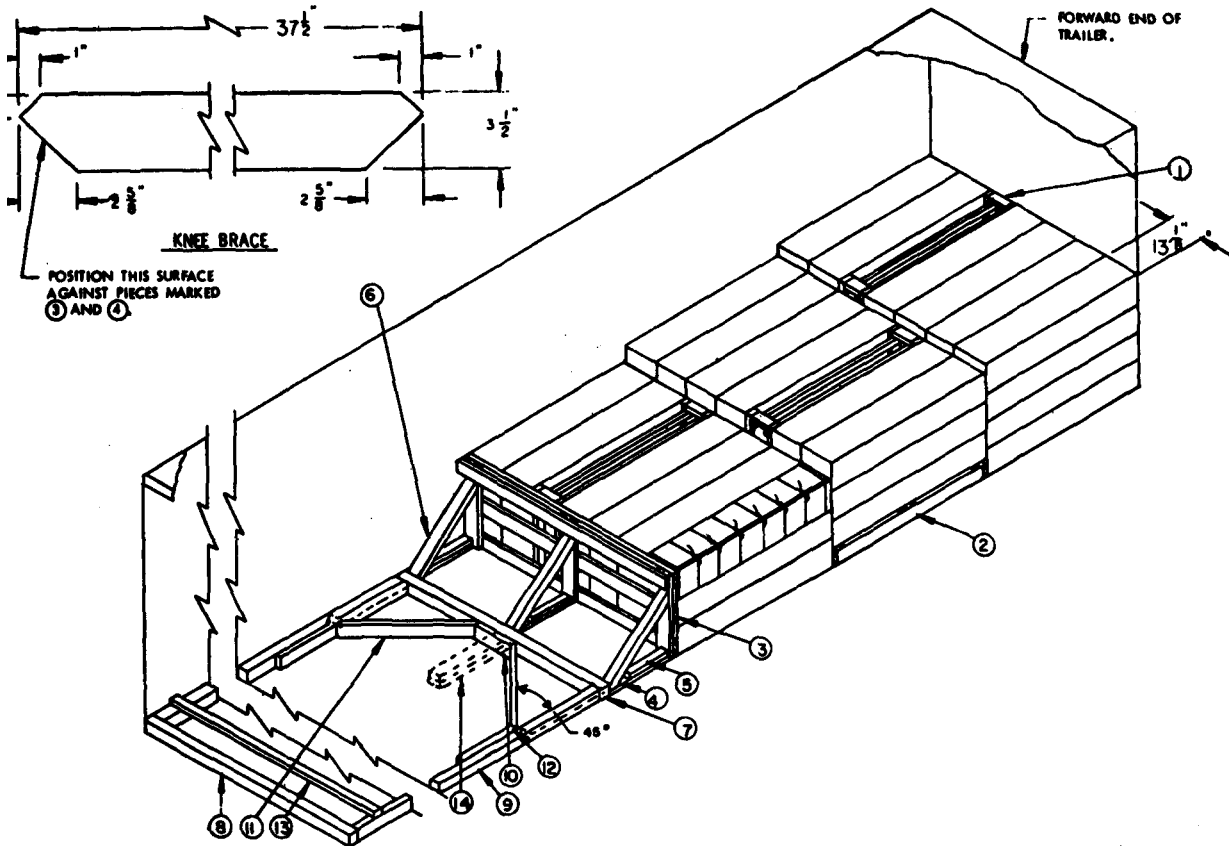

POSITION THIS SURFACE AGAINST PIECES MARKED ③ AND ④

ISOMETRIC VIEW

KEY NUMBERS

SPECIAL NOTES:

- THESE LTL OUTLOADING PROCEDURES ARE SHOWN DEPICTING THE USE OF "KNEE-BRACE" BLOCKING IN A 7'-6" WIDE TRAILER. WIDER OR NARROWER TRAILERS CAN BE USED.
- THE "K-BRACE" BLOCKING, SHOWN AS PIECES MARKED ⑥ THROUGH ⑬ IS ADEQUATE FOR RETAINING NOT MORE THAN 18,000 POUNDS OF LADING.
- PIECES MARKED ⑭ ARE FOR USE IN A TRAILER WHICH HAS A NAILABLE FLOOR AND SHOULD BE USED, IF POSSIBLE, IN LIEU OF PIECES MARKED ⑥ THROUGH ⑬ WHICH APPLY TO TRAILERS HAVING NON-NAILABLE FLOORS. THREE (3) BACK-UP CLEATS, SHOWN AS PIECES MARKED ⑫, ARE ADEQUATE FOR RETAINING A MAXIMUM SIZE LTL LOAD OF 15,000 POUNDS.
- SPACER ASSEMBLY, PIECES MARKED ①, SHOULD BE OFF-SET THROUGHOUT THE LENGTH OF THE LOAD AS SHOWN.
- A RISER, PIECE MARKED ②, MUST BE USED WHEN LONGITUDINALLY ADJACENT STACKS ARE STEPPED UP OR DOWN.
- IF THE TRAILER BEING LOADED HAS A ROUND-FRONT OR ROUNDED CORNERS AT THE FORWARD END, REFER TO PAGE 6 FOR "FORWARD BLOCKING ASSEMBLY".
- IF THE TRAILER BEING OUTLOADED CONTAINS MECHANICAL BRACING DEVICES THEY MAY BE USED IN LIEU OF PIECES MARKED ⑥ THRU ⑬. POSITION THE CROSS MEMBERS AT THE 4", 16" AND 28" HEIGHT DIMENSIONS FOR THE LOAD SHOWN ABOVE. INSTALL CROSS MEMBERS TIGHTLY AGAINST THE CONTAINERS.
- THE USE OF A RISER ASSEMBLY IS SPECIFIED FOR THE DEPICTED LOAD ONLY TO SHOW A TYPICAL APPLICATION. RISER ASSEMBLIES MAY BE USED IN THE LOAD AS REQUIRED TO ADJUST THE LOADING PATTERN FOR THE NUMBER OF CONTAINERS TO BE SHIPPED.

- ① SPACER ASSEMBLY (3 REQD). SEE THE "SPACER ASSEMBLY M" DETAIL ON PAGE 14. SEE SPECIAL NOTE 4 ON THIS PAGE.
- ② RISER ASSEMBLY (1 REQD). SEE THE "RISER ASSEMBLY I" DETAIL ON PAGE 14. SEE SPECIAL NOTES 4 AND 7 ON THIS PAGE.
- ③ REAR-OF-LOAD GATE (1 REQD). SEE THE "REAR-OF-LOAD GATE ASSEMBLY D" DETAIL ON PAGE 5.
- ④ FLOOR CLEAT, 2" X 4" BY CUT-TO-FIT (26-1/2" REF) (3 REQD).
- ⑤ POCKET CLEAT, 2" X 4" X 18" (3 REQD). NAIL TO PIECE MARKED ④ W/5-10d NAILS. TOENAIL TO THE VERTICAL PIECE ON REAR-OF-LOAD GATE, MARKED ③ W/2-12d NAILS.
- ⑥ KNEE BRACE, 4" X 4" X 37-1/2" (3 REQD). SEE THE "KNEE BRACE" DETAIL ABOVE FOR THE BEVEL CUTS REQUIRED. TOENAIL TO PIECES MARKED ③ AND ④ W/2-16d NAILS AT EACH END.
- ⑦ FORWARD HEADER, 4" X 4" BY TRAILER WIDTH MINUS 1/2" (1 REQD). TOENAIL TO PIECE MARKED ④ W/2-16d NAILS AT EACH JOINT.
- ⑧ REAR HEADER, 4" X 4" BY TRAILER WIDTH MINUS 1/2" (1 REQD). POSITION AGAINST REAR CORNER POSTS IF THE TRAILER IS SO EQUIPPED, OR POSITION TO CONTACT REAR DOORS OF THE TRAILER WHEN THEY ARE CLOSED. SEE SPECIAL NOTE 2 ON THIS PAGE.
- ⑨ SIDE STRUT, 4" X 4" BY CUT TO FIT BETWEEN PIECES MARKED ⑦ AND ⑧ (2 REQD). TOENAIL TO PIECES MARKED ⑦ AND ⑧ W/2-16d NAILS AT EACH END.
- ⑩ CENTER CLEAT, 2" X 4" X 18" (1 REQD). NAIL TO PIECE MARKED ⑦ W/4-12d NAILS.
- ⑪ DIAGONAL BRACE, 2" X 4" BY CUT-TO-FIT (2 REQD). DOUBLE BEVEL EACH END WITH 45° CUTS. INSTALL AT A 45° ANGLE AS SHOWN AND TOENAIL TO PIECES MARKED ⑦ AND ⑧ W/2-16d NAILS AT EACH END.
- ⑫ BACK-UP CLEAT, 2" X 4" X 24" (2 REQD). NAIL TO PIECE MARKED ⑨ W/6-12d NAILS.
- ⑬ STRUT BRACING, 2" X 4" BY TRAILER WIDTH (CUT TO FIT) (MINIMUM OF 1 REQD). INSTALL ONE (1) NEAR REAR END OF STRUTS MARKED ⑨ AS SHOWN. ONE (1) ADDITIONAL PIECE REQUIRED FOR EVERY 7'-0" OF STRUT LENGTH. NAIL TO PIECES MARKED ⑨ W/3-12d NAILS AT EACH END.
- ⑭ BACK-UP CLEAT, 2" X 4" X 30" (DOUBLED) (3 REQD). ALIGN WITH A KNEE BRACE MARKED ⑥ AND NAIL THE FIRST PIECE TO THE TRAILER FLOOR W/7-12d NAILS. NAIL THE SECOND PIECE TO THE FIRST IN A LIKE MANNER. SEE SPECIAL NOTE 3 ON THIS PAGE.

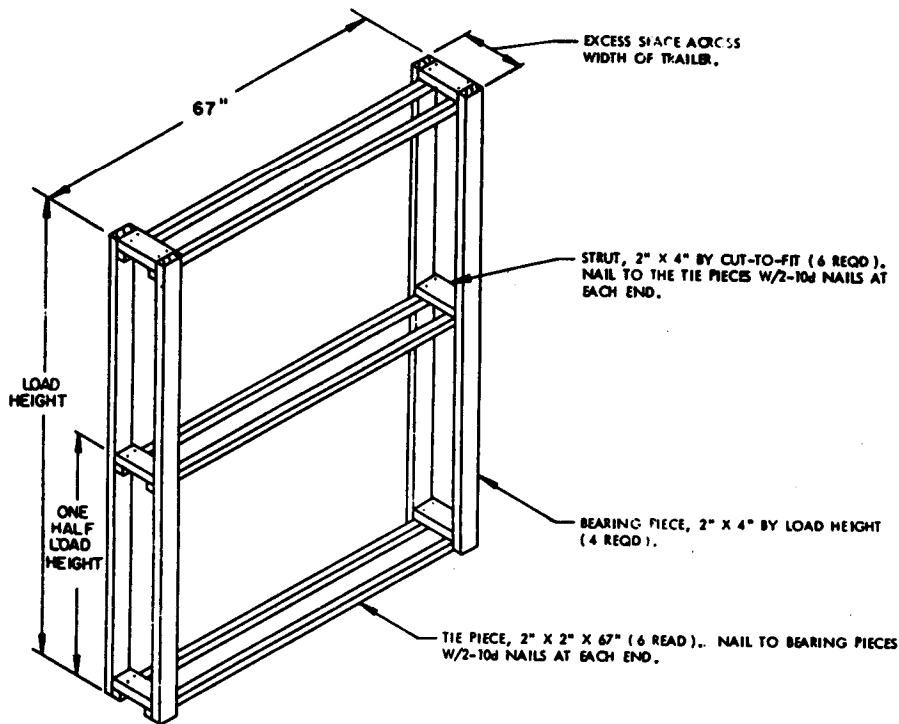

SPACER ASSEMBLY H

THIS SPACER ASSEMBLY IS DESIGNED FOR USE IN LOADS OF UNINITIALIZED WIREBOUND CONTAINERS.

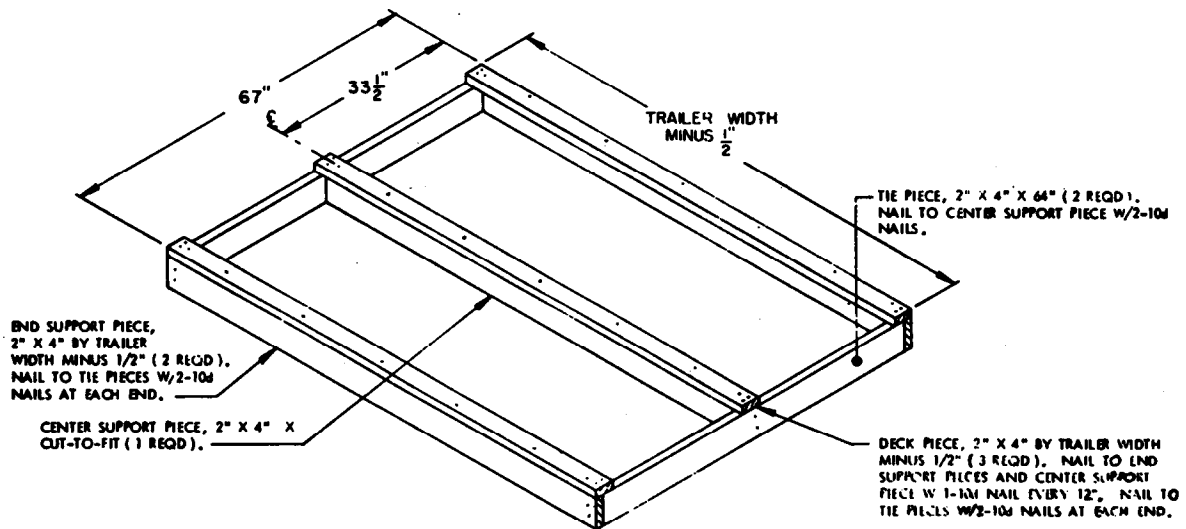

RISER ASSEMBLY I

THIS RISER ASSEMBLY IS DESIGNED FOR USE IN LOADS OF UNINITIALIZED WIREBOUND CONTAINERS.

CHAPTER 6

MARINE AND TERMINAL TRANSPORTABILITY GUIDANCE

6-1. Scope

This chapter provides marine and terminal transportability guidance for movement of the STINGER weapon system. It covers significant technical and physical characteristics and prescribes the materials and guidance required to prepare, load, and unload the items. Unloading is the reverse of loading.

NOTE

The methods described in this chapter for lifting and securing items are suggested procedures. Other methods of handling and stowage may be used, providing they will insure safe delivery without damage.

6-2. General Rules for Stowing Crated, Unitized, Palletized, or Containerized Loads

Crated, unitized, palletized, or containerized loads are blocked, braced, shored, lashed, and tommed, as required, to prevent movement. When loading, a full hold of large pieces, it is advantageous to leave wire

rope slings attached to the last piece loaded for ease of unloading.

6-3. Safety

In addition to the safety precautions contained in chapter 3, the following are applicable.

a. Missiles will be handled and stowed in accordance with provisions contained in 49 Code of Federal Regulations (CFR) or in Water Carriers Tariff No. 31 or reissues thereof.

b. Vessel equipment will be inspected as required by 46 CFR 146. Lifting devices (fig 6-1) must be included in the inspection. Note that one piece of 1/2-inch plywood, 42 by 60 inches, is banded on top of the load to protect the load from sling abrasion.

6-4. Lifting and Loading

Figure 6-1 is a lifting diagram for crated, unitized, or palletized loads. Containerized loads are lifted with the special container adapter slings normally used in a port or terminal for the type of container used.

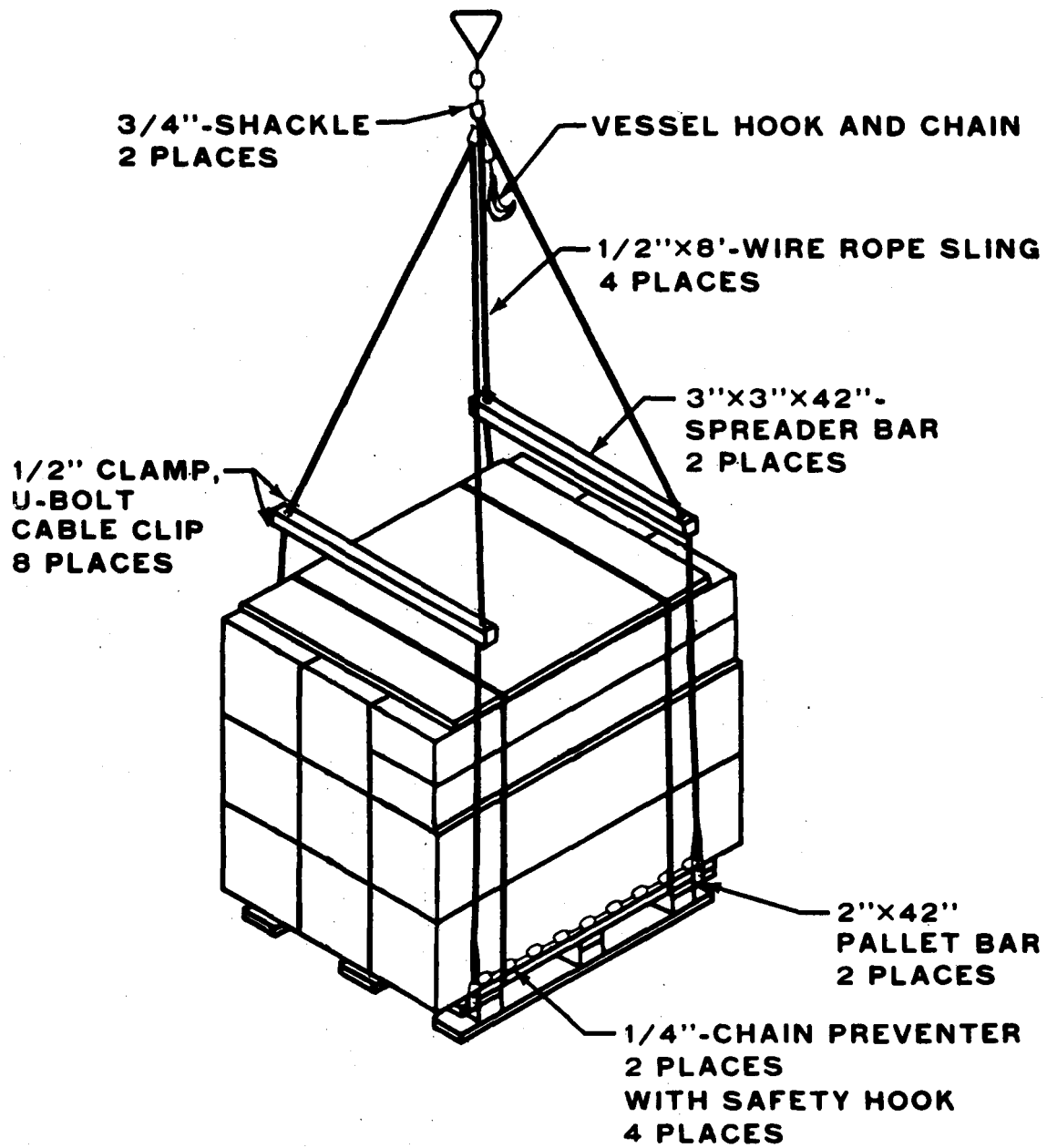

Figure 6-1. Lifting diagram for crated, unitized or palletized loads of STINGER weapon system items.

CHAPTER 7

RAIL TRANSPORTABILITY GUIDANCE

Section I. GENERAL

7.1. Scope

This chapter provides rail transportability guidance for movement of the STINGER weapon system, XFIM-92A in shipping and storage containers. It covers significant technical and physical characteristics and prescribes the materials and guidance

required to prepare, load, tie down, and unload the items.

7-2. Maximum Utilization of Railcars

Additional cargo, as approved by the activity offering the items for transport, may be transported with the items.

Section II. TRANSPORT ON CONUS RAILWAYS

7-3. General

The transportability guidance in this section is applicable when the items are transported on CONUS railways. All items, when loaded on suitable railcars, can be transported without sectionalization or major disassembly within the Association of American Railroads Outline Diagram for Single Loads, Without End Overhang, on Open-Top Cars, as shown in both the *Railway Line Clearance Publications* and the *Official Railway Equipment Register*.

7-4. Preparation of Items

The degree of preparation of the items prior to being transported is dependent upon the operational commitment.

7-5. Loading

a. The STINGER weapon system items in shipping and storage containers may be loaded one at a time, or in unitized packages, into boxcars by use of a forklift.

b. After placement at the securing position, the items will be secured in accordance with figure 7-1.

NOTE

Figure 7-1 is extracted from US Army Development and Research Command missile drawing number 5514 GM 5SR1.

Complete drawing, pages through 88, may be obtained from S Army Defense Ammunition Center and School (SARAC-DEV) Savanna, IL 61074.

Section III. TRANSPORT ON FOREIGN RAILWAYS

7-6. General

The transportability guidance contained in this section is applicable when the STINGER missiles system is transported on foreign railways. The items can be transported without restrictions on all foreign national boxcars. Because of the various designation systems used by different countries,

foreign railcars are not easily classified. Consequently, evaluation of transportability capability must be made on an individual basis. The STINGER weapon system shipping and storage containers can be loaded in foreign railway boxcars, using methods similar to those used for securing the items on American railroad cars.

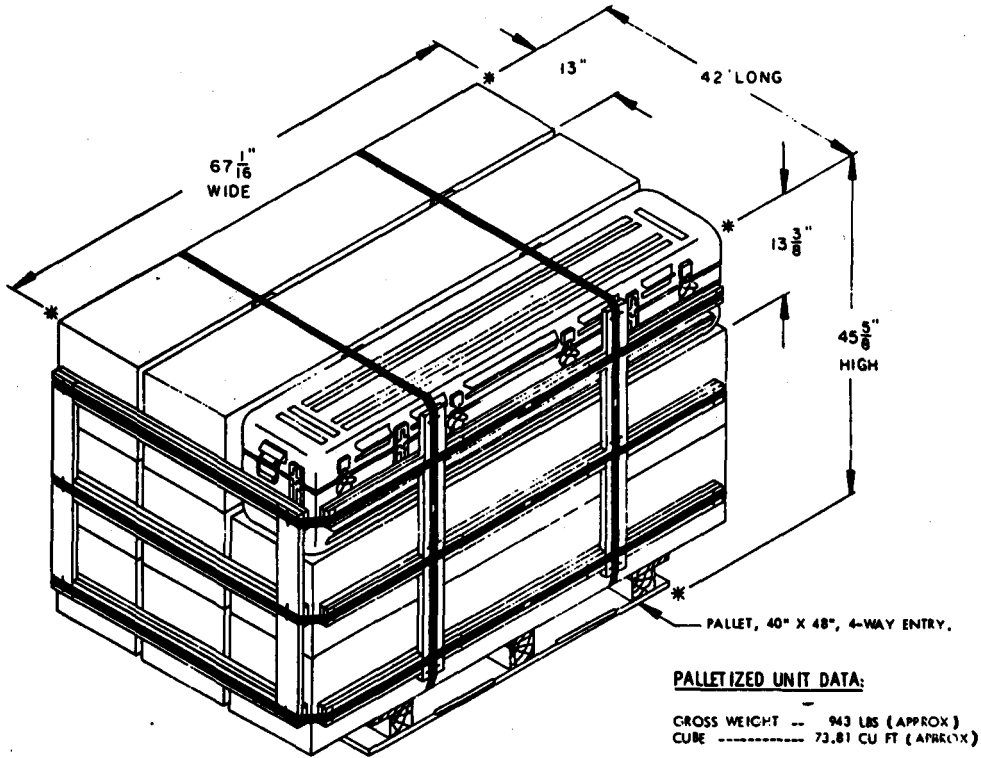

**PALLETIZED UNIT OF NINE (9) GUIDED MISSILES,
PACKED ONE (1) PER ALUMINUM CONTAINER.**

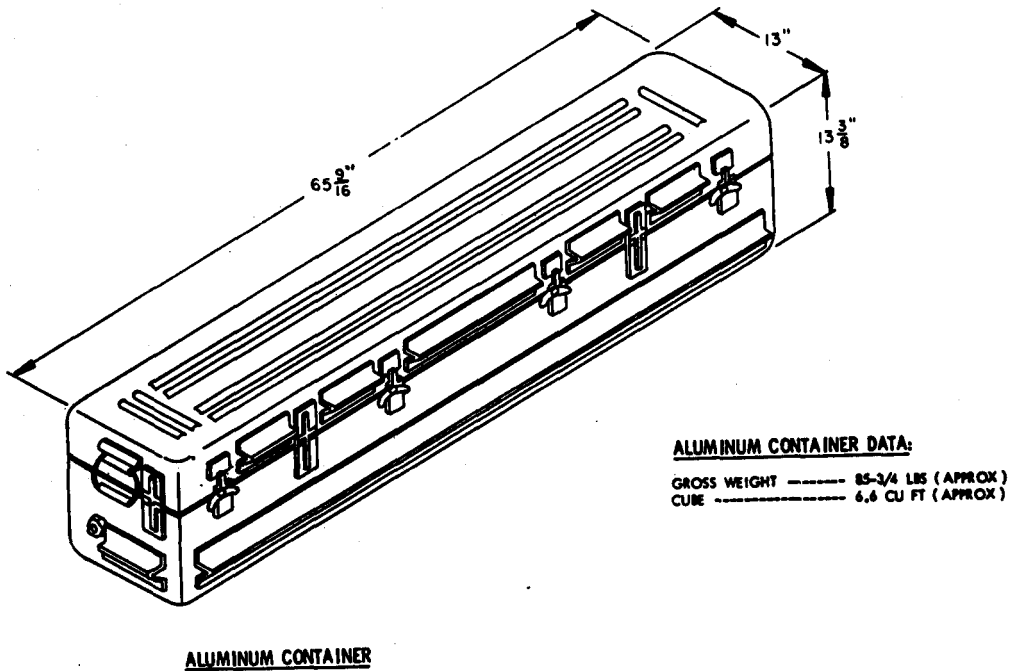
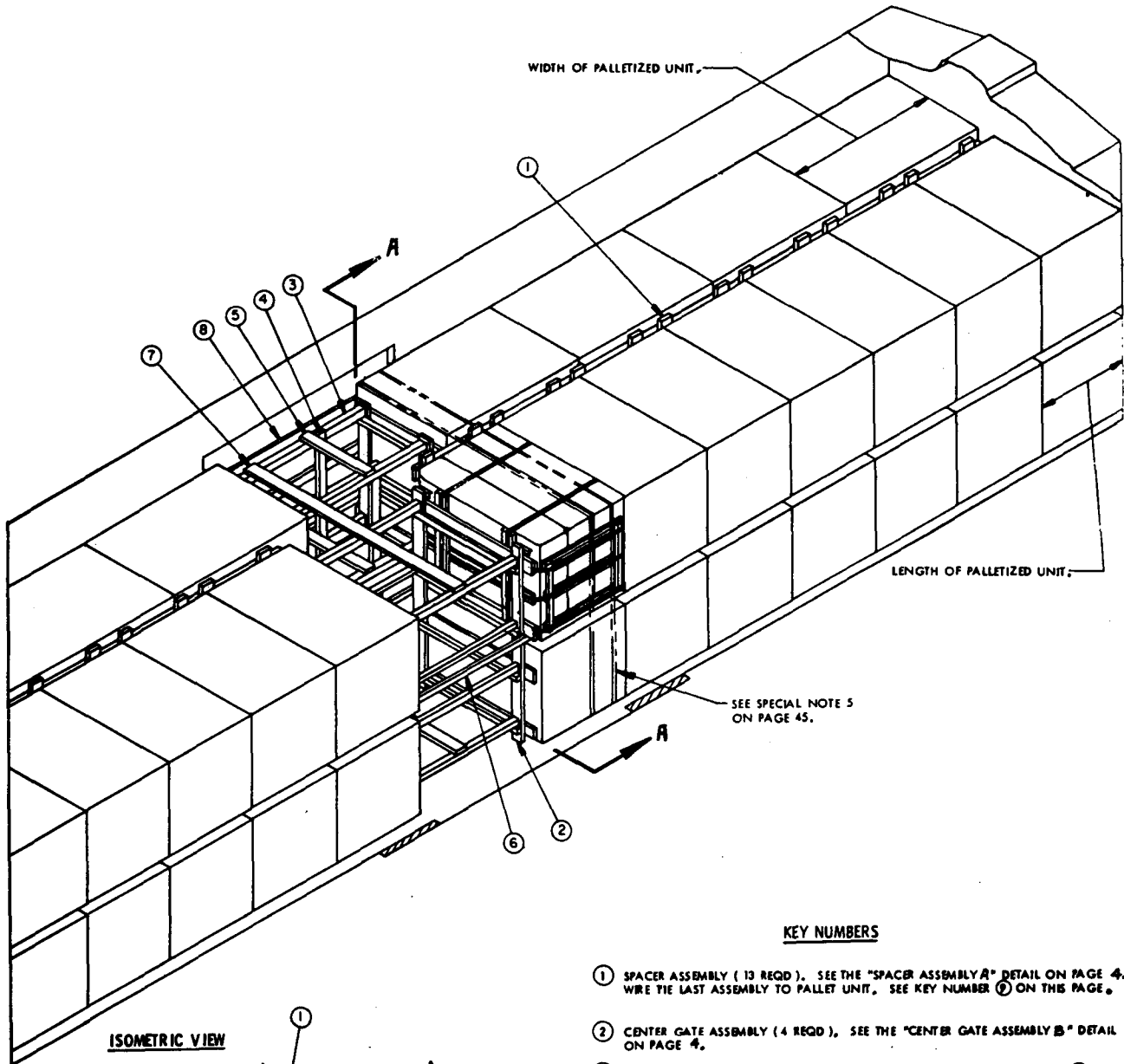
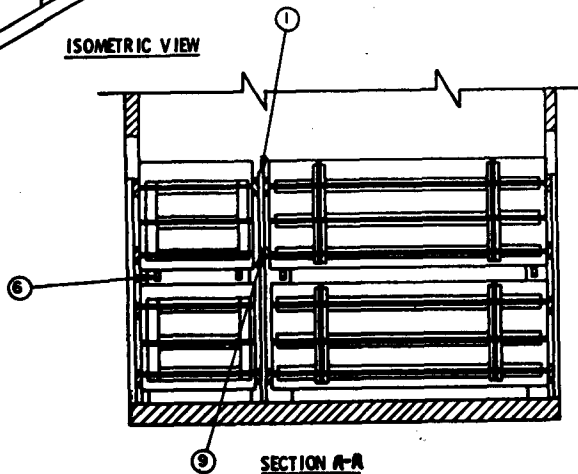

Figure 7-1. Loading and bracing (CL and LCL) of STINGER weapon system complete round in boxcars, packed in wirebound and/or aluminum container (unitized and ununitized or palletized and unpalletized) (sheets 1 through 18).



KEY NUMBERS

- ① SPACER ASSEMBLY (13 REQD). SEE THE "SPACER ASSEMBLY A" DETAIL ON PAGE 4. WIRE TIE LAST ASSEMBLY TO PALLET UNIT. SEE KEY NUMBER ② ON THIS PAGE.
- ② CENTER GATE ASSEMBLY (4 REQD), SEE THE "CENTER GATE ASSEMBLY B" DETAIL ON PAGE 4.
- ③ STRUT, 4" X 4" BY CUT-TO-FIT (16 REQD), TOENAIL TO PIECES MARKED ② W/2-16d NAILS AT EACH END.
- ④ VERTICAL STRUT BRACING, 2" X 4" BY CUT-TO-EXTEND 2" ABOVE TOP STRUT (2 REQD), NAIL TO THE STRUTS W/3-16d NAILS AT EACH JOINT.
- ⑤ HORIZONTAL STRUT BRACING, 2" X 4" BY CUT-TO-FIT (4 REQD), NAIL TO THE STRUTS W/3-16d NAILS AT EACH JOINT.
- ⑥ GATE HOLD-DOWN, 2" X 4" CENTER SPACE PLUS 18" (4 REQD), NAIL TO VERTICAL ON "CENTER GATE ASSEMBLY B" W/2-16d NAILS AT EACH JOINT.
- ⑦ ANTI-SWAY BOARD, 2" X 4" BY CUT-TO-FIT (2 REQD), POSITION ACROSS TOP AND BOTTOM LAYER STRUTS, CENTER ON THE SHORT STRUTS AND NAIL W/3-16d NAILS AT EACH JOINT.
- ⑧ DOORWAY PROTECTION GATE (2 REQD), SEE "DOORWAY PROTECTION GATE C" DETAIL ON PAGE 4. SEE SPECIAL NOTE 5 ON PAGE 3.
- ⑨ TIE WIRE, NO. 14 GAGE WIRE BY LENGTH-TO-SUIT (4 REQD), WIRE TIE THE LAST "SPACER ASSEMBLY A" TO THE UNITIZING STRAPS ON THE ADJACENT PALLETIZED UNIT.



SPECIAL NOTES:

1. A 50'-6" LONG BY 9'-6" WIDE CONVENTIONAL TYPE BOX CAR EQUIPPED WITH 8'-0" WIDE DOOR OPENINGS IS SHOWN. CARS OF OTHER DIMENSIONS AND CARS HAVING WIDER OR NARROWER DOOR OPENINGS CAN BE USED.
2. A WIDER OR NARROWER CAR CAN BE USED FOR SHIPPING THE DEPICTED LOAD BY ADJUSTING THE WIDTH OF THE "SPACER ASSEMBLY A". ADDITIONAL PIECES OF 6" WIDE MATERIAL MAY BE LAMINATED TO THE HORIZONTAL PIECES OR PIECES OF 1" THICK BY 6" WIDE MATERIAL MAY BE USED IN LIEU OF THE 2" THICK BY 6" WIDE MATERIAL.
3. IF THE CAR BEING LOADED HAS "THRU" PLUG DOORS OR STAGGERED PLUG DOORS OF ANY WIDTH, "BUNDLING STRAPS" AS SHOWN IN THE "PLUG DOOR PROCEDURES" ON THIS PAGE WILL BE REQUIRED. IF THE CAR BEING LOADED HAS STAGGERED CONVENTIONAL SLIDING DOORS (ANY WIDTH) OR "THRU" CONVENTIONAL SLIDING DOORS (ANY WIDTH), DOORWAY PROTECTION GATES, SHOWN AS PIECE MARKED (B) ON PAGE 2, WILL ALWAYS BE REQUIRED TO RETAIN THE PALLETIZED UNITS.
4. IF THE CAR BEING LOADED HAS BOWED END WALLS WHICH ARE BOWED OUTWARD TWO INCHES (2") OR MORE EITHER FROM SIDE-TO-SIDE OR FROM FLOOR-TO-ROOF, AN END-OF-CAR BULKHEAD MUST BE INSTALLED TO PROVIDE A "SQUARED OFF" SURFACE FOR THE LOAD AT THE END OF THE CAR.

BUNDLING STRAP, 1-1/4" X .035" X 36'-0" LONG (REF) STEEL STRAPPING (AS REQD), INSTALL SO AS TO ENCIRCLE THE LOAD UNITS IN THE DOORWAY AREA. SEAL WITH TWO 1-1/4" SEALS PER EACH STRAP. DOUBLE CRIMP EACH SEAL.

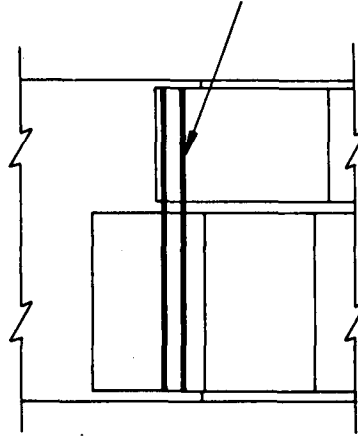

PLUG DOOR PROCEDURES

THESE PROCEDURES WILL APPLY TO PLUG DOORS WHETHER AUXILIARY OR MAIN. FOR EACH STACK OF PALLETIZED UNITS WHICH EXTENDS MORE THAN ONE-HALF (1/2) OF ITS LENGTH OR WIDTH PAST A DOOR POST INTO THE DOORWAY AREA ON ONE OR BOTH SIDES OF THE CAR BEING LOADED, ONE BUNDLING STRAP IS REQUIRED. FOR EACH STACK OF PALLETIZED UNITS WHICH EXTENDS MORE THAN THREE-QUARTHS (3/4) OF ITS LENGTH OR WIDTH PAST A DOOR POST INTO THE DOORWAY AREA, TWO BUNDLING STRAPS ARE REQUIRED.

BILL OF MATERIAL		
LUMBER	LINEAR FEET	BOARD FEET
1" X 6"	64	32
2" X 2"	63	21
2" X 3"	28	7
2" X 4"	74	30
2" X 6"	510	510
4" X 4"	79	106
NAILS	NO. REQD	POUNDS
6d (2")	48	1/2
10d (3")	560	8-3/4
16d (3-1/2")	32	1-3/4
WIRE, NO. 14 GAGE	12' REQD	NIL

LOAD AS SHOWN

ITEM	QUANTITY	WEIGHT (APPROX)
PALLETIZED UNITS	42	39,404 LBS.
DUNNAGE		1,463 LBS.
TOTAL WEIGHT		41,067 LBS.

42 PALLETIZED UNITS OF ALUMINUM CONTAINERS IN A 50'-6" LONG BY 9'-6" WIDE CONVENTIONAL BOX CAR

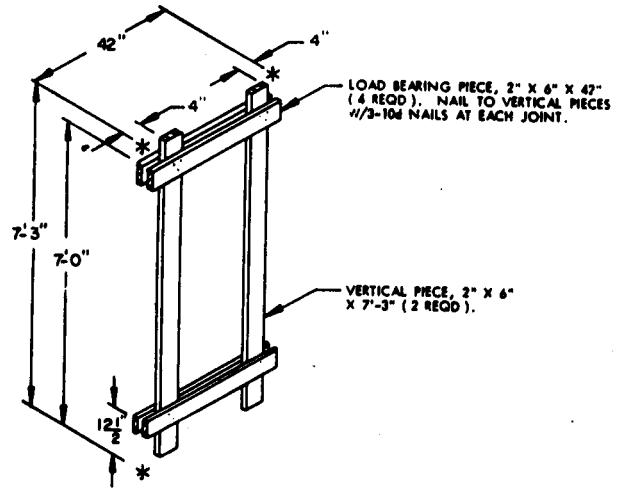

SPACER ASSEMBLY A

FOR USE WITH PALLETIZED ALUMINUM CONTAINERS. WHEN FABRICATING THIS ASSEMBLY, FIELD CHECK THE 12-1/2" AND 7'-0" DIMENSIONS FOR THE LOAD BEARING PIECES TO ASSURE THEY WILL BE IN LINE WITH THE HORIZONTAL DUNNAGE ON THE PALLETIZED UNIT.

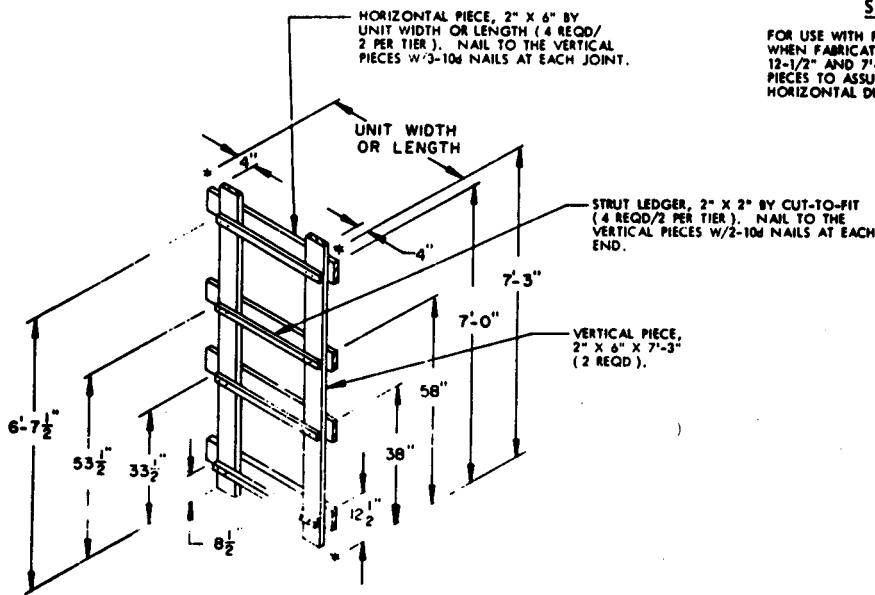

CENTER GATE ASSEMBLY B

FOR USE WITH PALLETIZED ALUMINUM CONTAINERS. THE GATE SHOWN ABOVE IS FOR A TWO TIER LOAD.

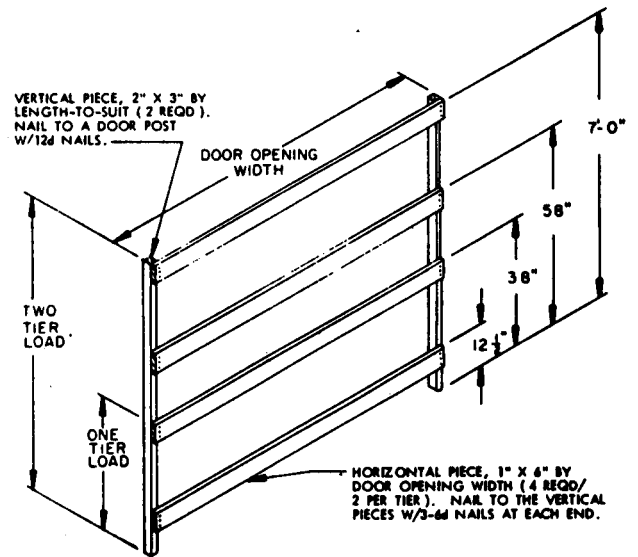

DOORWAY PROTECTION GATE C

FOR USE WITH PALLETIZED ALUMINUM CONTAINERS. THE GATE SHOWN IS FOR A TWO TIER LOAD.

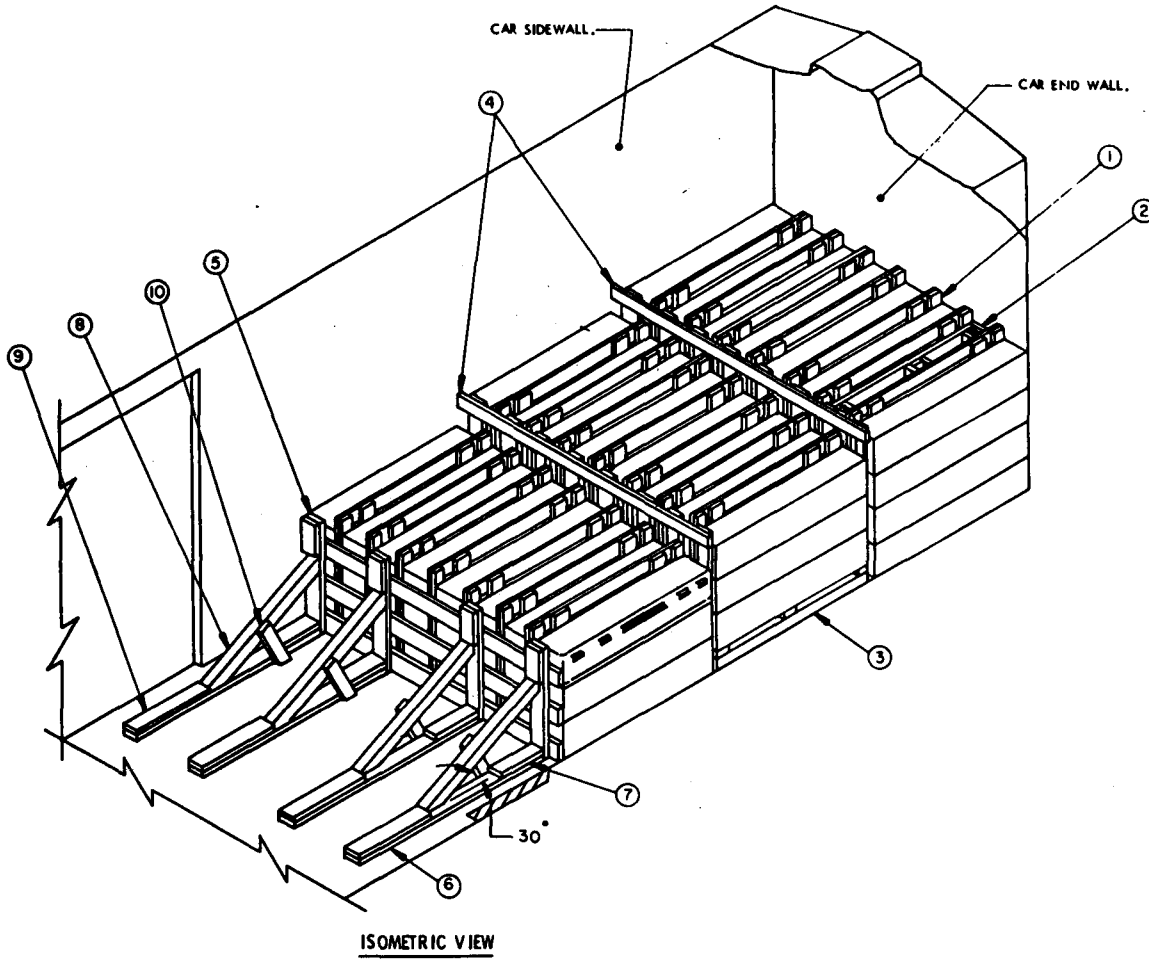

ISOMETRIC VIEW

KEY NUMBERS

- ① SPACER ASSEMBLY (21 REQD). SEE THE "SPACER ASSEMBLY B" DETAIL ON PAGE 8.
- ② FILLER ASSEMBLY (1 REQD). SEE THE "FILLER ASSEMBLY B" DETAIL ON PAGE 7. SEE SPECIAL NOTES 4 AND 6 ON PAGE .
- ③ RISER ASSEMBLY (1 REQD). SEE THE "RISER ASSEMBLY B" DETAIL ON PAGE 7. SEE SPECIAL NOTES 5 AND 6 ON PAGE .
- ④ SEPARATOR GATE ASSEMBLY (2 REQD). SEE THE "SEPARATOR GATE ASSEMBLY B" DETAIL ON PAGE 9.
- ⑤ LCL GATE ASSEMBLY (1 REQD). SEE THE "LCL GATE ASSEMBLY H" DETAIL ON PAGE 6.
- ⑥ FLOOR CLEAT, 2" X 6" X 6'-2-1/2" (4 REQD), ALIGN WITH VERTICAL PIECES ON THE LCL GATE ASSEMBLY AND NAIL TO THE CAR FLOOR W/1-16d NAIL EVERY 8".
- ⑦ SUPPORT PIECE, 2" X 6" X 18" (4 REQD). NAIL TO PIECE MARKED ⑥ W/4-16d NAILS AND TOENAIL TO THE VERTICAL PIECES OF THE LCL GATE ASSEMBLY W/2-12d NAILS.
- ⑧ DIAGONAL BRACE, 4" X 4" X 57" (4 REQD). SEE THE "DIAGONAL BRACE Z" DETAIL ON THIS PAGE FOR BEVEL CUTS REQUIRED. TOENAIL TO THE VERTICAL PIECE ON THE LCL GATE ASSEMBLY AND THE FLOOR CLEAT W/2-16d NAILS AT EACH END.
- ⑨ BACK-UP CLEAT, 2" X 6" X 30" (4 REQD). NAIL TO PIECE MARKED ⑥ W/6-40d NAILS.
- ⑩ DIAGONAL BRACE SUPPORT, 2" X 4" BY CUT-TO-FIT (4 REQD). BEVEL THE BOTTOM END WITH A 60° CUT. CENTER ON THE DIAGONAL BRACE AND NAIL TO PIECES MARKED ⑥ AND ⑧ W/2-12d NAILS AT EACH END.

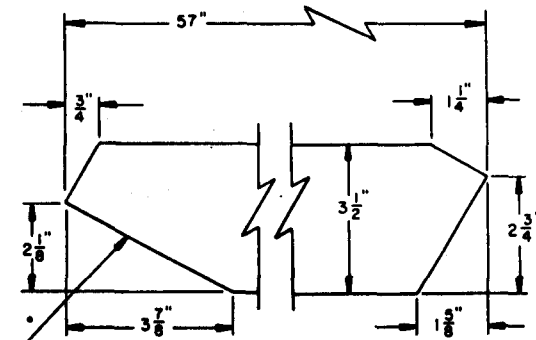

THIS BRACE MUST BE INSTALLED SO THAT THIS BEARING SURFACE WILL BE IN CONTACT WITH THE FLOOR CLEAT MARKED ⑥.

DIAGONAL BRACE Z

SPECIAL NOTES:

1. A TYPICAL LCL LOAD OF 79 ALUMINUM CONTAINERS IS SHOWN IN A 9'-2" WIDE CONVENTIONAL TYPE BOX CAR HAVING A WOOD OR NAILABLE METAL FLOOR. CARS OF OTHER WIDTHS CAN BE USED.
2. FOUR KNEE BRACE ASSEMBLIES AS SHOWN ARE ADEQUATE FOR RETAINING A MAXIMUM SIZE LCL LOAD.
3. IF THE LADING EXTENDS INTO THE DOORWAY AREA MORE THAN ONE-HALF OF AN ALUMINUM CONTAINER LENGTH, USE "DOORWAY PROTECTION GATE 3" DETAIL ON PAGE 9.
4. FILLER ASSEMBLIES, SHOWN AS PIECE MARKED ②, MAY BE USED AS REQUIRED IN THE TOP LAYER ONLY. DO NOT USE IN THE LAYER ADJACENT TO THE LCL GATE ASSEMBLY.
5. A RISER ASSEMBLY, SHOWN AS PIECE MARKED ③, MAY BE USED TO STEP DOWN ALUMINUM CONTAINERS AS SHOWN TO MEET THE REQUIREMENTS OF SPECIAL NOTE 7. DO NOT USE UNDER THE STACK ADJACENT TO THE LCL GATE ASSEMBLY.
6. THE USE OF THE "RISER ASSEMBLY" AND THE "FILLER ASSEMBLY" ARE SPECIFIED FOR THE DEPICTED LOAD ONLY TO SHOW A TYPICAL APPLICATION. THEY MAY BE USED IN THE LOAD AS REQUIRED TO ADJUST THE LOADING PATTERN FOR THE QUANTITY OF CONTAINERS TO BE SHIPPED.
7. THE MAXIMUM STACK HEIGHT ADJACENT TO THE LCL GATE ASSEMBLY IS THREE (3) CONTAINERS HIGH.
8. THE ALUMINUM CONTAINERS MUST BE POSITIONED WITH THE 13" DIMENSION ACROSS THE CAR WIDTH AS SHOWN IN THE "ISOMETRIC VIEW" ON PAGE 5.
9. IF THE CAR BEING LOADED IS LESS THAN 9'-2" WIDE, ONLY SEVEN (7) ALUMINUM CONTAINERS CAN BE POSITIONED ACROSS THE CAR WIDTH.
10. IF THE CAR BEING LOADED HAS BOWED END WALLS WHICH ARE BOWED OUTWARD TWO INCHES (2") OR MORE EITHER FROM SIDE-TO-SIDE OR FROM FLOOR-TO-ROOF, AN END-OF-CAR BULKHEAD MUST BE INSTALLED TO PROVIDE A "SQUARED OFF" SURFACE FOR THE LOAD AT THE END OF THE CAR.
11. POSITION THE DIAGONAL BRACE, SHOWN AS PIECE MARKED ⑧, TIGHT AGAINST THE HOLD-DOWN CLEAT ON THE LCL GATE ASSEMBLY AND IN LINE WITH THE INSIDE EDGE OF THE FLOOR CLEAT, AS SHOWN ABOVE, TO FACILITATE POSITIONING OF THE DIAGONAL BRACE SUPPORT, SHOWN AS PIECE MARKED ⑩ ON PAGE 5.

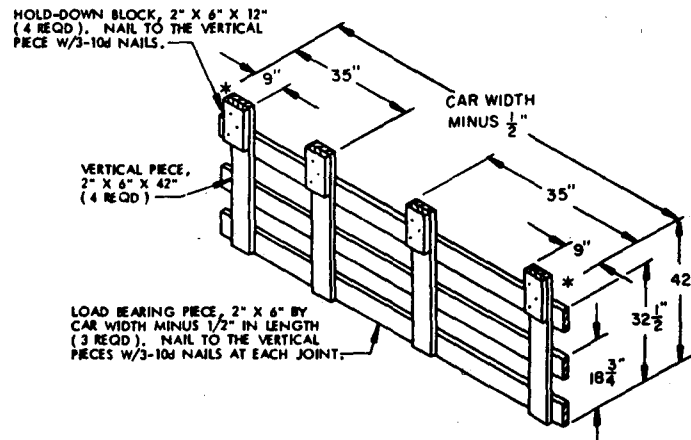

LCL GATE ASSEMBLY M

TYPICAL LCL USING KNEE BRACE METHOD

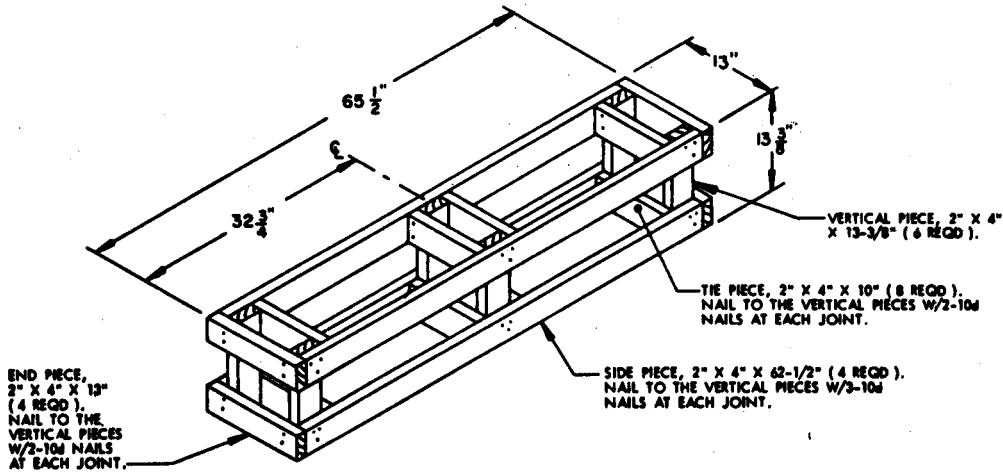

FILLER ASSEMBLY D

THE FILLER ASSEMBLY SHOWN ABOVE IS TO BE USED WITHIN LOADS TO TAKE THE PLACE OF AN OMITTED ALUMINUM CONTAINER. IT MUST BE USED IN THE TOP LAYER ONLY.

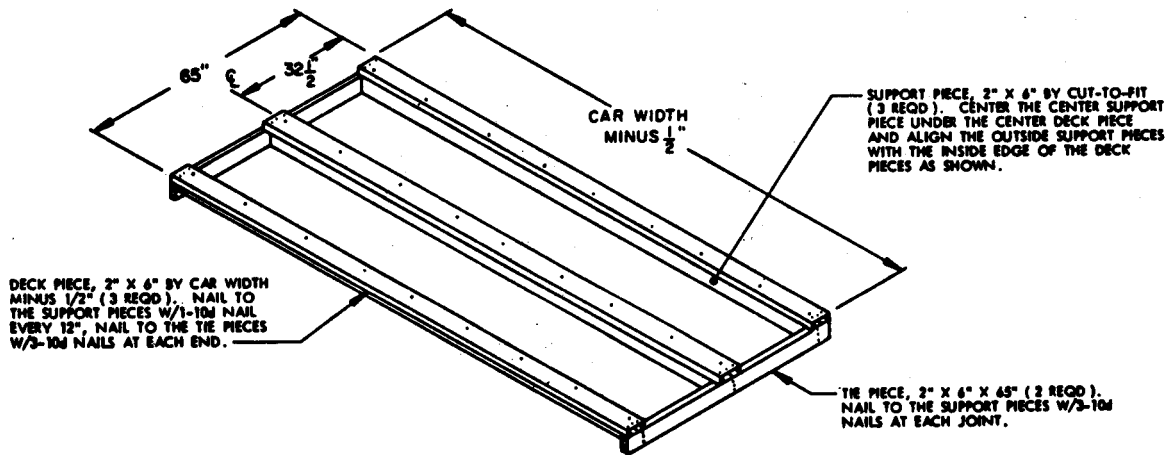

RISER ASSEMBLY F

FOR USE WITH UNPALLETIZED ALUMINUM CONTAINERS.

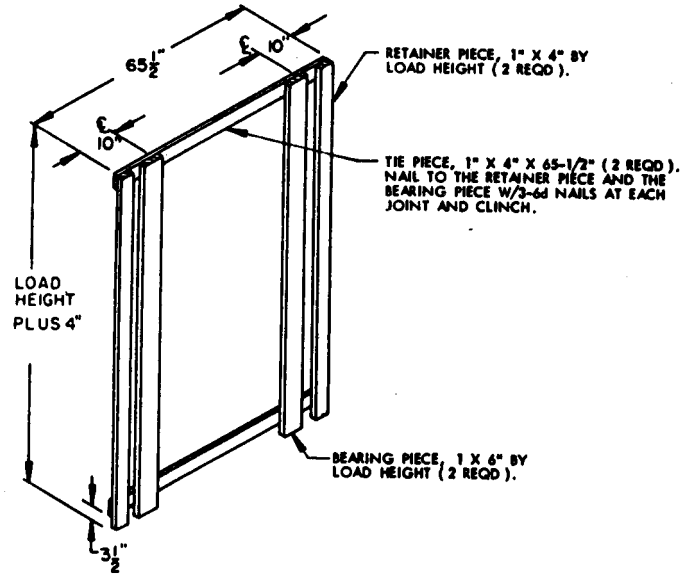

SPACER ASSEMBLY A

FOR USE WITH UNPALLETIZED ALUMINUM CONTAINERS.

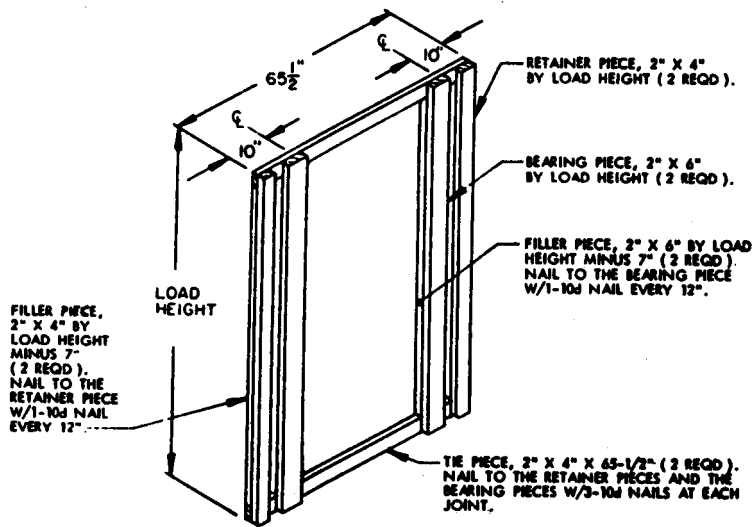

SPACER ASSEMBLY B

FOR USE WITH UNPALLETIZED ALUMINUM CONTAINERS.

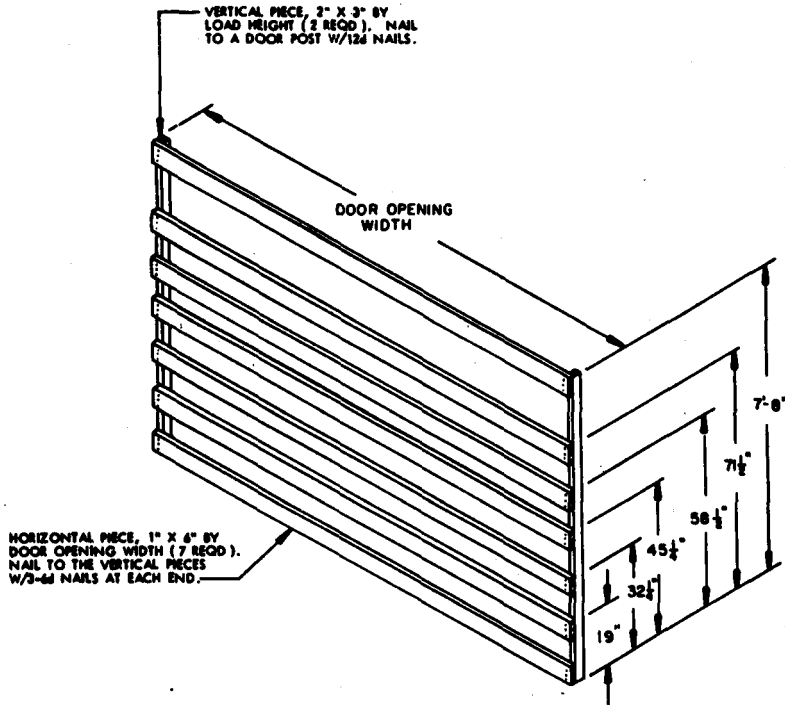

DOORWAY PROTECTION GATE J

FOR USE WITH UNPALLETIZED ALUMINUM CONTAINERS. THE GATE SHOWN ABOVE IS FOR A SEVEN TIER LOAD. SEE "CHART R" ON THIS PAGE FOR A LOAD OF LESS THAN SEVEN CONTAINERS HIGH.

CHART R							
LAYERS OF CNTRS	HEIGHT OF HORIZONTAL PIECES REQUIRED						
	2	5-1/2"	26-1/2"	*	*	*	*
3	5-1/2"	19"	39-3/4"	*	*	*	*
4	5-1/2"	19"	32-1/4"	32-3/4"	*	*	*
5	5-1/2"	19"	32-1/4"	45-1/4"	66"	*	*
6	5-1/2"	19"	32-1/4"	45-1/4"	58-1/2"	79"	*
7	5-1/2"	19"	32-1/4"	45-1/4"	58-1/2"	71-1/2"	92"

* HORIZONTAL PIECE IS NOT REQUIRED.

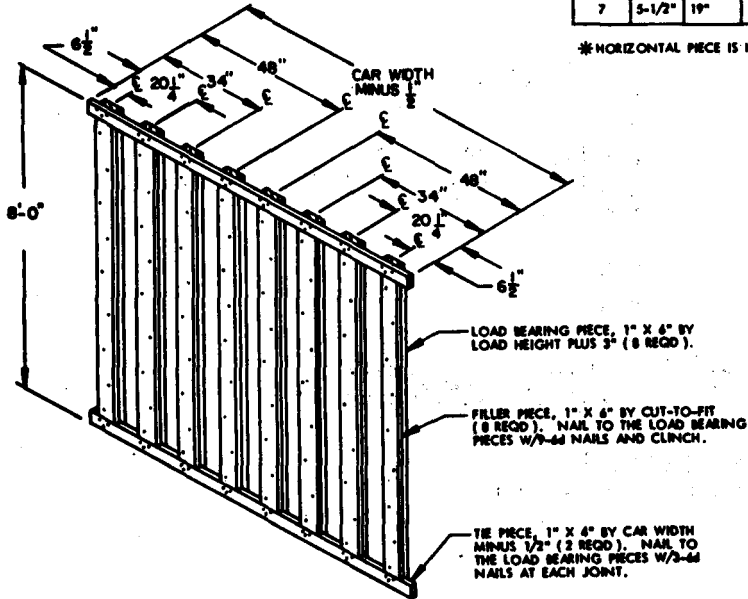

SEPARATOR GATE ASSEMBLY G

FOR USE WITH UNPALLETIZED ALUMINUM CONTAINERS. THE GATE SHOWN ABOVE IS FOR A SEVEN TIER LOAD. FOR LOADS OF OTHER HEIGHTS, THE LOAD BEARING PIECES WILL BE 1" X 6" BY LOAD HEIGHT PLUS 3".

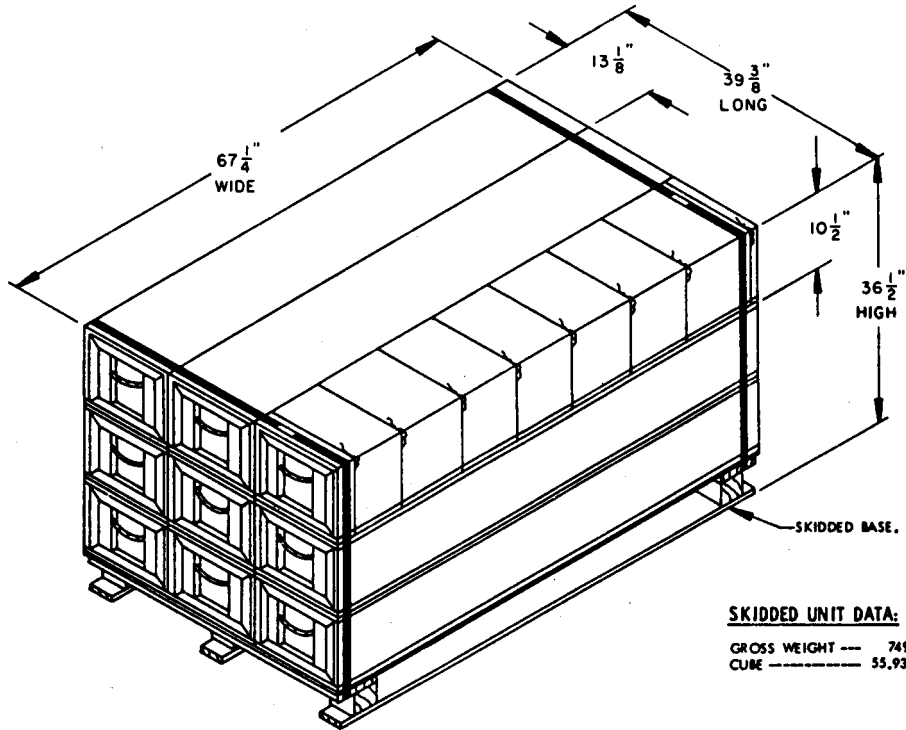

SKIDDED UNIT DATA:

GROSS WEIGHT --- 749 LBS (APPROX)
 CUBE ----- 55.93 CU FT (APPROX)

**SKIDDED UNIT OF NINE (9) GUIDED MISSILES,
 PACKED ONE (1) PER WIREBOUND (WOODEN) BOX**

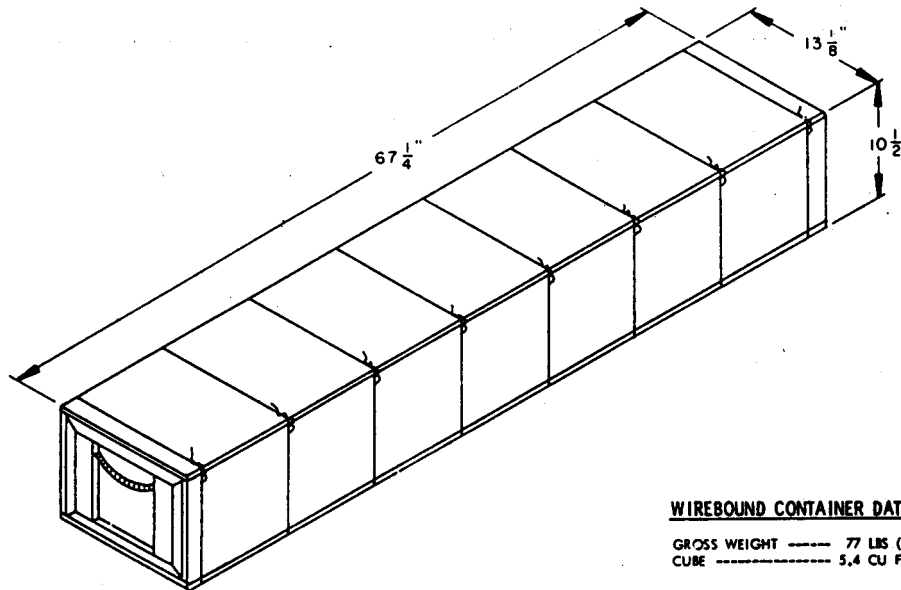

WIREBOUND CONTAINER DATA:

GROSS WEIGHT ----- 77 LBS (APPROX)
 CUBE ----- 5.4 CU FT (APPROX)

WIREBOUND CONTAINER

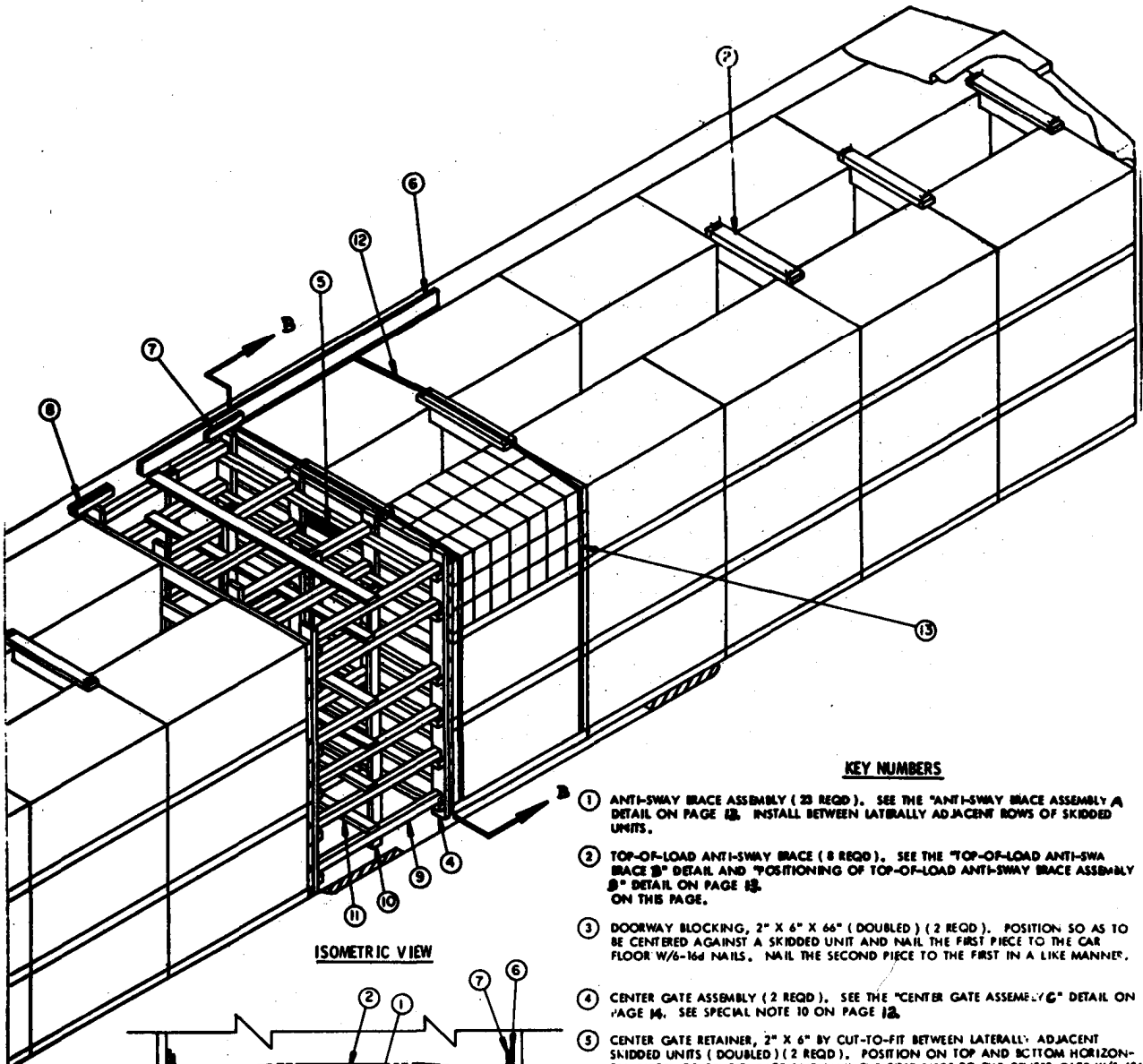

ISOMETRIC VIEW

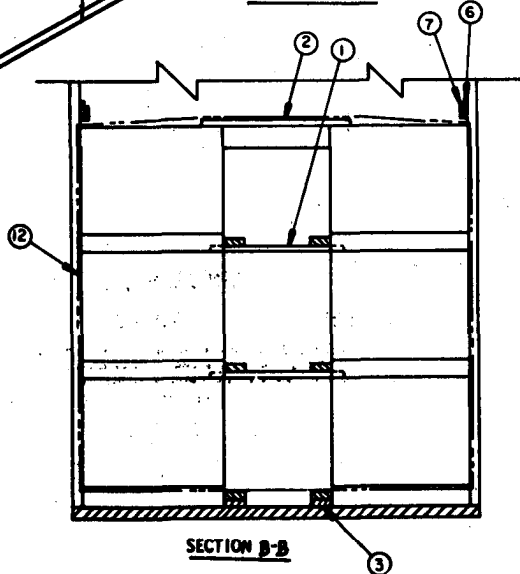

SECTION B-B

KEY NUMBERS

- ① ANTI-SWAY BRACE ASSEMBLY (28 REQ'D). SEE THE "ANTI-SWAY BRACE ASSEMBLY A" DETAIL ON PAGE 12. INSTALL BETWEEN LATERALLY ADJACENT ROWS OF SKIDDED UNITS.
- ② TOP-OF-LOAD ANTI-SWAY BRACE (8 REQ'D). SEE THE "TOP-OF-LOAD ANTI-SWAY BRACE B" DETAIL AND "POSITIONING OF TOP-OF-LOAD ANTI-SWAY BRACE ASSEMBLY B" DETAIL ON PAGE 13. ON THIS PAGE.
- ③ DOORWAY BLOCKING, 2" X 6" X 66" (DOUBLED) (2 REQ'D). POSITION SO AS TO BE CENTERED AGAINST A SKIDDED UNIT AND NAIL THE FIRST PIECE TO THE CAR FLOOR W/6-16d NAILS. NAIL THE SECOND PIECE TO THE FIRST IN A LIKE MANNER.
- ④ CENTER GATE ASSEMBLY (2 REQ'D). SEE THE "CENTER GATE ASSEMBLY C" DETAIL ON PAGE 14. SEE SPECIAL NOTE 10 ON PAGE 12.
- ⑤ CENTER GATE RETAINER, 2" X 6" BY CUT-TO-FIT BETWEEN LATERALLY ADJACENT SKIDDED UNITS (DOUBLED) (2 REQ'D). POSITION ON TOP AND BOTTOM HORIZONTAL PIECES OF CENTER GATE AND NAIL THE FIRST PIECE TO THE CENTER GATE W/5-10d NAILS. NAIL THE SECOND PIECE TO THE FIRST IN A LIKE MANNER.
- ⑥ CENTER GATE HOLD-DOWN, 2" X 6" BY DOOR OPENING WIDTH PLUS 24" (2 REQ'D). NAIL TO THE CAR SIDE WALL W/5-12d NAILS AT EACH END.
- ⑦ CENTER GATE HOLD-DOWN CLEAT, 2" X 4" X 18" (2 REQ'D). CENTER THE CLEATS ABOVE THE VERTICAL PIECES ON THE CENTER GATE AND NAIL TO PIECE MARKED ④ W/5-10d NAILS.
- ⑧ CENTER GATE HOLD-DOWN CLEAT, 2" X 4" X 18" (DOUBLED) (2 REQ'D). CENTER THE CLEATS ABOVE THE VERTICAL PIECES ON THE CENTER GATE AND NAIL THE FIRST PIECE TO THE CAR SIDE WALL W/5-10d NAILS. NAIL THE SECOND PIECE TO THE FIRST IN A LIKE MANNER.
- ⑨ STRUT, 4" X 4" BY CUT-TO-FIT (24 REQ'D). TOENAIL TO PIECE MARKED ④ W/2-16d NAILS AT EACH END.
- ⑩ VERTICAL STRUT BRACING, 2" X 4" BY CUT-TO-EXTEND 2" ABOVE TOP STRUT (4 REQ'D). NAIL TO THE STRUTS W/3-10d NAILS AT EACH JOINT.
- ⑪ HORIZONTAL STRUT BRACING, 2" X 4" BY CAR WIDTH MINUS 1/2" (6 REQ'D). NAIL TO THE STRUTS W/3-10d NAILS AT EACH JOINT.
- ⑫ DOORWAY PROTECTION STRAP, 1-1/4" X .035" X 38'-0" LONG (REF) STEEL STRAPPING (2 REQ'D). INSTALL SO AS TO ENIRCLE THE LOAD UNITS IN THE DOORWAY AREA. SECURE TO PIECE MARKED ③ W/2 STAPLES. SEE SPECIAL NOTE 8 ON PAGE 12.
- ⑬ SEAL FOR 1-1/4" STRAPPING (4 REQ'D, 2 PER STRAP). DOUBLE CRIMP EACH SEAL.

48 SKIDDED UNITS OF WIREBOUND CONTAINERS IN A 50'-6" LONG BY 9'-2" WIDE CONVENTIONAL BOX CAR

SPECIAL NOTES:

1. A 50'-6" LONG BY 9'-2" WIDE CONVENTIONAL TYPE BOX CAR EQUIPPED WITH 10'-0" WIDE DOOR OPENINGS IS SHOWN. CARS OF OTHER DIMENSIONS AND CARS HAVING WIDER OR NARROWER DOOR OPENINGS CAN BE USED.
2. TOP-OF-LOAD ANTI-SWAY BRACES MUST BE INSTALLED ON THE FIRST TWO (2) STACKS AT EACH END OF THE BOX CAR, AS SHOWN ON PAGE 11, AND WIRE TIE TO A UNITIZING STRAP WITH NO. 14 GAGE WIRE AS SHOWN BY THE "POSITIONING OF TOP-OF-LOAD ANTI-SWAY BRACE ASSEMBLY" DETAIL ON PAGE 18. USE TWO (2) TOP-OF-LOAD ANTI-SWAY BRACES ON TOP OF THE TWO STACKS WITHIN THE DOORWAY AREA OF THE CAR, AS SHOWN ON PAGE 11.
3. A WIDER OR NARROWER CAR CAN BE USED FOR SHIPPING THE DEPICTED LOAD BY ADJUSTING THE PIECES MARKED ① AND ②.
4. IF THE CAR BEING LOADED HAS "THRU" PLUG DOORS OR STAGGERED PLUG DOORS OF ANY WIDTH, DOORWAY PROTECTION STRAPS, SHOWN AS PIECE MARKED ⑫ ON PAGE 11, WILL BE REQUIRED. IF THE CAR BEING LOADED HAS STAGGERED CONVENTIONAL SLIDING DOORS (ANY WIDTH) OR "THRU" CONVENTIONAL SLIDING DOORS (ANY WIDTH), DOORWAY PROTECTION STRAPS, SHOWN AS PIECE MARKED ⑫, ON PAGE 11, WILL BE REQUIRED.
5. FOR EACH LOAD UNIT OF SIX SKIDDED UNITS WHICH EXTENDS MORE THAN 33" PAST A DOOR POST INTO THE DOORWAY AREA ON ONE OR BOTH SIDES OF THE CAR BEING LOADED, ONE (1) SET OF PIECES MARKED ②, ③, ⑫, AND ⑬ MUST BE INSTALLED TO BUNDLE THAT UNIT. FOR EACH LOAD UNIT OF SIX SKIDDED UNITS WHICH EXTENDS 34" OR MORE PAST A DOOR POST INTO THE DOORWAY AREA, PIECES MARKED ③ AND TWO (2) SETS OF PIECES MARKED ②, ⑫, AND ⑬ MUST BE INSTALLED TO BUNDLE THAT UNIT AS SHOWN WITHIN THE BASIC LOAD VIEWS.
6. THE SPECIFIC BLOCKING AND BRACING DUNNAGE AND THE BASIC METHOD OF APPLICATION IS ALSO ADEQUATE FOR RETAINING A FULL LOAD IN A 40'-6" LONG BY 8'-6" WIDE CAR. THIRTY-SIX (36) SKIDDED UNITS MAY BE SHIPPED IN A 40'-6" LONG CAR, WITH 24 UNITS LOADED WITHIN ONE END OF THE CAR AND 12 UNITS LOADED WITHIN THE OTHER END. ADJUST QUANTITIES OF DUNNAGE AS REQUIRED.
7. IF THE CAR BEING LOADED HAS BOWED END WALLS WHICH ARE BOWED OUTWARD TWO INCHES (2") OR MORE EITHER FROM SIDE-TO-SIDE OR FROM FLOOR-TO-ROOF, AN END-OF-CAR BULKHEAD MUST BE INSTALLED TO PROVIDE A "SQUARED OFF" SURFACE FOR THE LOAD AT THE END OF THE CAR.

BILL OF MATERIAL		
LUMBER	LINEAR FEET	BOARD FEET
2" X 2"	110	37
2" X 4"	270	180
2" X 6"	494	494
4" X 4"	145	194
NAILS	NO. REQD	POUNDS
10d (3")	658	10-1/4
16d (3-1/2")	120	2-3/4
STEEL STRAPPING, 1-1/4" X .035" ----- 76' REQD ----- 11 LBS		
SEAL FOR 1-1/4" STRAPPING ----- 4 REQD ----- NIL		
WIRE, NO. 14 GAGE ----- 32' REQD ----- NIL		

LOAD AS SHOWN		
ITEM	QUANTITY	WEIGHT (APPROX)
SKIDDED UNIT	48	38,952 LBS
DUNNAGE		1,834 LBS
TOTAL WEIGHT		40,786 LBS

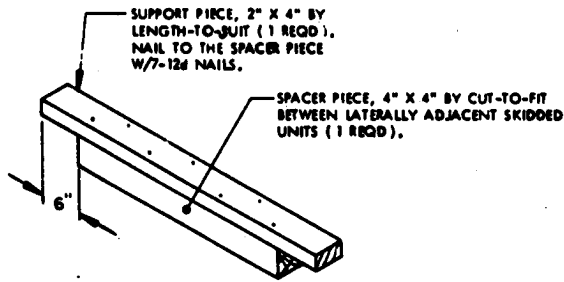

TOP-OF-LOAD ANTI-SWAY BRACE ASSEMBLY B

THIS ASSEMBLY IS DESIGNED FOR USE BETWEEN THE TOP OF LATERALLY ADJACENT SKIDDED UNITS OF WIREBOUND CONTAINERS. POSITION BETWEEN STACKS IN EACH END OF CAR TO PREVENT UNITS FROM TOPPLING INTO VOID AREA. THE ASSEMBLY WILL BE WIRE TIED TO THE SKIDDED UNIT UNITIZING STRAP TO PREVENT DISPLACEMENT.

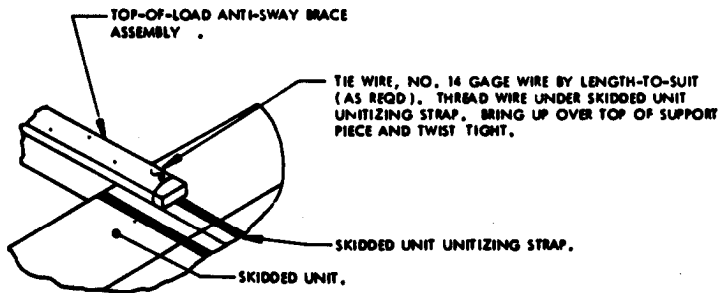

POSITIONING OF TOP-OF-LOAD ANTI-SWAY BRACE ASSEMBLY B

THIS VIEW DEPICTS THE SECUREMENT OF A TOP-OF-LOAD ANTI-SWAY BRACE TO THE TOP OF A SKIDDED UNIT BY WIRE TYING TO THE UNITIZING STRAPS WITH NO. 14 GAGE WIRE.

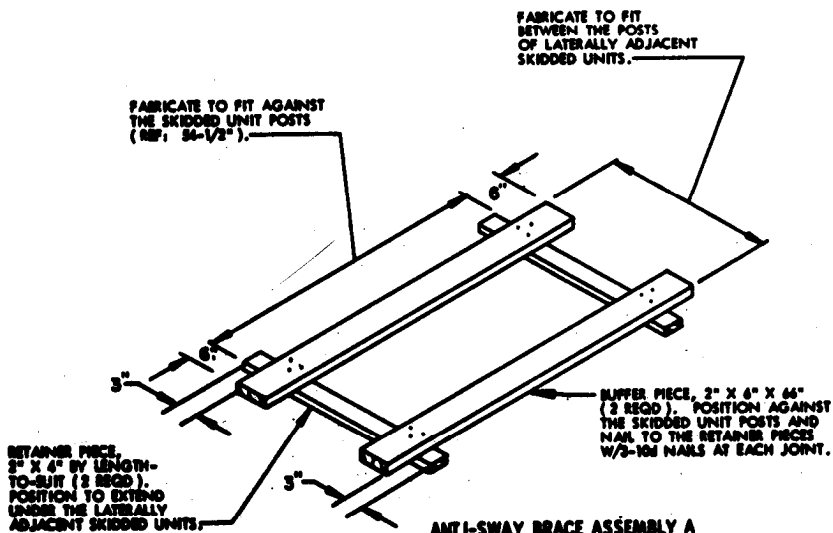

ANTI-SWAY BRACE ASSEMBLY A

FOR USE WITH UNITIZED WIREBOUND CONTAINERS. SEE THE "POSITIONING OF ANTI-SWAY BRACE ASSEMBLY A" ON THIS PAGE.

POSITIONING OF ANTI-SWAY BRACE ASSEMBLY A:

1. THE "ANTI-SWAY BRACE ASSEMBLY A" MUST BE FABRICATED IN PLACE BETWEEN LATERALLY ADJACENT SKIDDED UNITS.
 - A. POSITION THE FIRST RETAINER PIECE JUST BEHIND THE NEAR POSTS ON LATERALLY ADJACENT SKIDDED UNITS, SPANNING THE VOID BETWEEN THEM AND RESTING ON THE BOTTOM BOARDS OF THE SKIDDED UNITS.
 - B. POSITION A 2" X 6" X 66" BUFFER PIECE 3" FROM THE END OF THE FIRST RETAINER PIECE AND EXTENDING 5-3/4" BEYOND THE EDGE OF THE FIRST RETAINER PIECE. NAIL THE BUFFER PIECE TO THE RETAINER PIECE W/3-10d NAILS.
 - C. KEEPING THE FIRST BUFFER PIECE AGAINST THE 181" OF A SKIDDED UNIT, POSITION THE SECOND BUFFER PIECE AGAINST THE SIDE OF THE LATERALLY ADJACENT SKIDDED UNIT AND EXTENDING 5-3/4" BEYOND THE EDGE OF THE FIRST RETAINER PIECE. NAIL THE BUFFER PIECE TO THE RETAINER PIECE W/3-10d NAILS.
 - D. HOLD THE ENDS OF BOTH BUFFER PIECES AND PUSH THE PARTIAL ASSEMBLY FORWARD UNTIL THE FIRST RETAINER PIECE CONTACTS THE SKIDDED UNIT POSTS ON THE FAR END.
 - E. POSITION THE SECOND RETAINER PIECE JUST BEHIND AND CONTACTING THE NEAR POSTS ON LATERALLY ADJACENT SKIDDED UNITS.
 - F. KEEP THE TWO BUFFER PIECES AGAINST THE SIDES OF THE LATERALLY ADJACENT SKIDDED UNITS AND NAIL EACH ONE TO THE SECOND RETAINER PIECE W/3-10d NAILS.

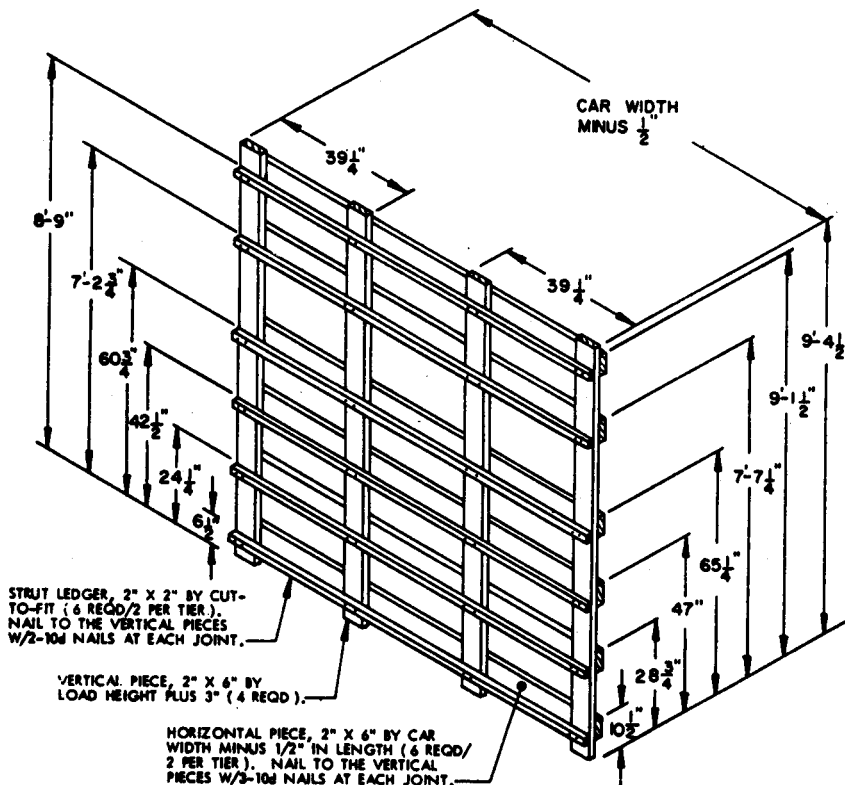

CHART B (SEE NOTE BELOW)

UNITS HIGH	HEIGHT OF HORIZONTAL PIECES REQUIRED					
1 TIER	19"	36-1/2"	*	*	*	*
2 TIERS	10-1/2"	28-3/4"	53"	73"	*	*
3 TIERS	10-1/2"	28-3/4"	47"	65-1/4"	91-1/4"	109-1/2"

NOTE:
 WHEN FABRICATING GATES FOR THREE TIER LOADS OR LESS, USE "CHART B" ABOVE FOR PROPER LOCATION OF THE HORIZONTAL PIECES. ONE STRUT LEDGER, POSITIONED ON THE OPPOSITE SIDE OF THE VERTICAL PIECES IS REQUIRED FOR EACH HORIZONTAL PIECE ON THE GATE. THE TOP EDGE OF EACH STRUT LEDGER WILL BE LOCATED 4-1/2" BELOW THE TOP EDGE OF THE MATED HORIZONTAL PIECE. EACH VERTICAL PIECE WILL BE CUT-TO-EXTEND 3" ABOVE THE TOP HORIZONTAL PIECE.

* HORIZONTAL PIECE IS NOT REQUIRED.

CENTER GATE ASSEMBLY C

FOR USE WITH UNITIZED WIREBOUND CONTAINERS. THE GATE SHOWN ABOVE IS FOR A THREE TIER LOAD. SEE "CHART B" ON THIS PAGE FOR A ONE OR TWO TIER LOAD.

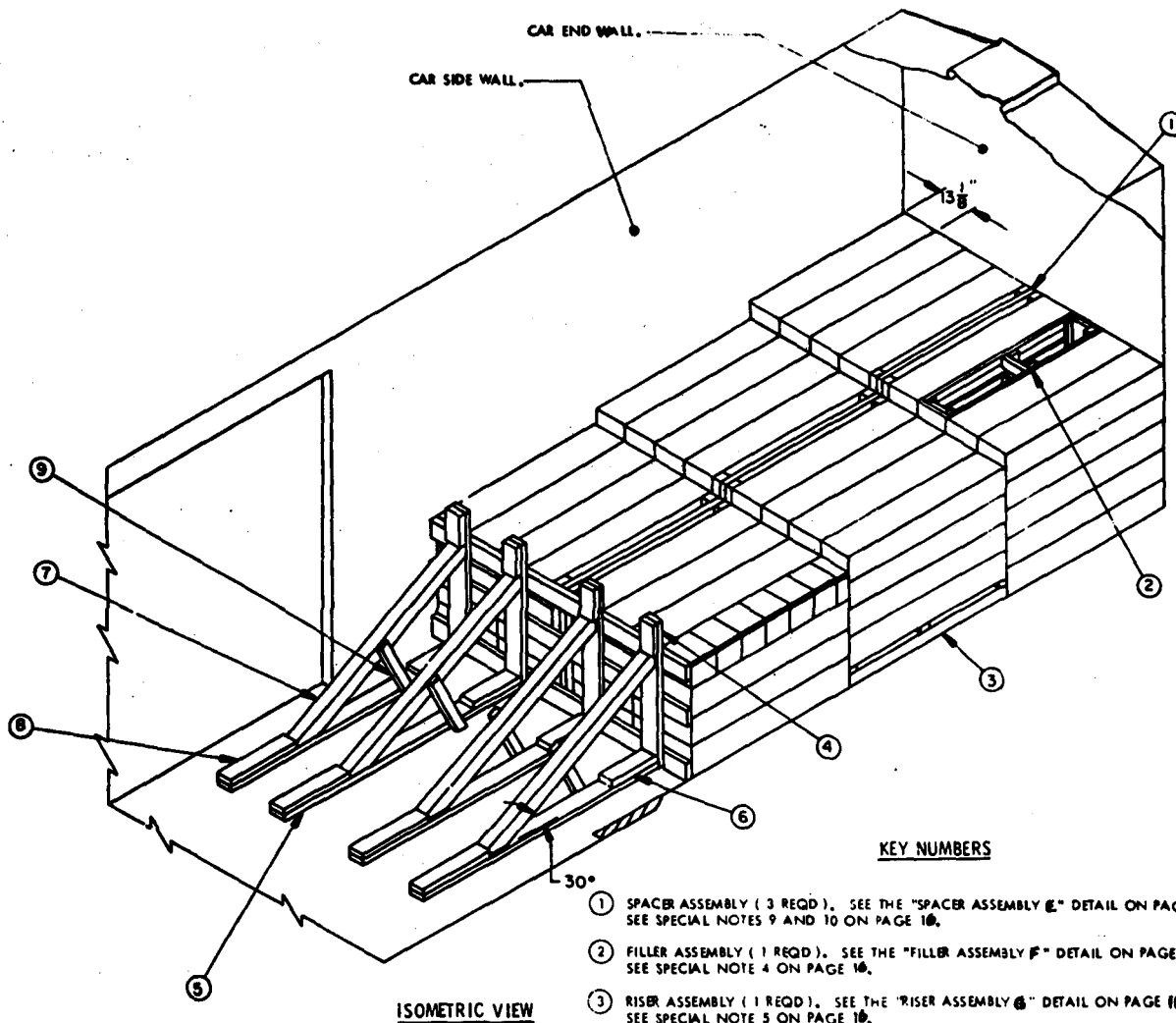

ISOMETRIC VIEW

KEY NUMBERS

- ① SPACER ASSEMBLY (3 REQD). SEE THE "SPACER ASSEMBLY E" DETAIL ON PAGE 17. SEE SPECIAL NOTES 9 AND 10 ON PAGE 18.
- ② FILLER ASSEMBLY (1 REQD). SEE THE "FILLER ASSEMBLY F" DETAIL ON PAGE 17. SEE SPECIAL NOTE 4 ON PAGE 18.
- ③ RISER ASSEMBLY (1 REQD). SEE THE "RISER ASSEMBLY G" DETAIL ON PAGE 18. SEE SPECIAL NOTE 5 ON PAGE 18.
- ④ LCL GATE ASSEMBLY (1 REQD). SEE THE "LCL GATE ASSEMBLY H" DETAIL ON PAGE 18 AND SPECIAL NOTE 7 ON PAGE 16.
- ⑤ FLOOR CLEAT, 2" X 6" X 8'-4" (4 REQD). ALIGN WITH VERTICAL PIECES ON THE LCL GATE ASSEMBLY AND NAIL TO THE CAR FLOOR W/1-16d NAIL EVERY 8". SEE GENERAL NOTE "K" ON PAGE 2.
- ⑥ SUPPORT PIECE, 2" X 6" X 18" (4 REQD). NAIL TO PIECE MARKED ③ W/4-16d NAILS AND TOENAIL TO THE VERTICAL PIECES OF THE LCL GATE ASSEMBLY W/2-12d NAILS.
- ⑦ DIAGONAL BRACE, 4" X 4" X 6'-9" (4 REQD). SEE THE "DIAGONAL BRACE D" DETAIL ON THIS PAGE FOR BEVEL CUTS REQUIRED. TOENAIL TO THE VERTICAL PIECE ON THE LCL GATE ASSEMBLY AND THE FLOOR CLEAT W/2-16d NAILS AT EACH END. SEE SPECIAL NOTE 12 ON PAGE 16.
- ⑧ BACK-UP CLEAT, 2" X 6" X 30" (4 REQD). NAIL TO PIECE MARKED ⑤ W/6-40d NAILS.
- ⑨ DIAGONAL BRACE SUPPORT, 2" X 4" BY CUT-TO-FIT (4 REQD). BEVEL THE BOTTOM END WITH A 60° CUT. CENTER ON THE DIAGONAL BRACE AND NAIL TO PIECES MARKED ⑤ AND ⑦ W/2-12d NAILS AT EACH END.

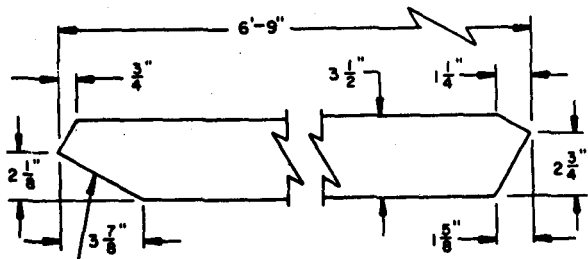

DIAGONAL BRACE D

THIS BRACE MUST BE INSTALLED SO THAT THIS BEARING SURFACE WILL BE IN CONTACT WITH THE FLOOR CLEAT MARKED ⑤.

SPECIAL NOTES:

1. A TYPICAL LCL LOAD OF 103 WIREBOUND CONTAINERS IS SHOWN IN A 9'-2" WIDE CONVENTIONAL TYPE BOX CAR HAVING A WOOD OR NAILABLE METAL FLOOR. CARS OF OTHER WIDTHS CAN BE USED.
2. FOUR KNEE BRACE ASSEMBLIES AS SHOWN ARE ADEQUATE FOR RETAINING A MAXIMUM SIZE LCL LOAD.
3. IF THE LADING EXTENDS INTO THE DOORWAY AREA MORE THAN ONE-HALF OF A WIREBOUND CONTAINER LENGTH, USE "DOORWAY PROTECTION GATE I" ON THIS PAGE.
4. FILLER ASSEMBLIES, SHOWN AS PIECE MARKED ②, MAY BE USED AS REQUIRED IN THE TOP LAYER ONLY. DO NOT USE IN THE LAYER ADJACENT TO THE LCL GATE ASSEMBLY.
5. A RISER ASSEMBLY, SHOWN AS PIECE MARKED ③, MAY BE USED TO STEP DOWN WIREBOUND CONTAINERS AS SHOWN TO MEET THE REQUIREMENTS OF SPECIAL NOTE 7. DO NOT USE UNDER THE STACK ADJACENT TO THE LCL GATE ASSEMBLY.
6. THE USE OF THE "RISER ASSEMBLY" AND THE "FILLER ASSEMBLY" ARE SPECIFIED FOR THE DEPICTED LOAD ONLY TO SHOW A TYPICAL APPLICATION. THEY MAY BE USED IN THE LOAD AS REQUIRED TO ADJUST THE LOADING PATTERN FOR THE QUANTITY OF CONTAINERS TO BE SHIPPED.
7. THE MAXIMUM STACK HEIGHT ADJACENT TO THE LCL GATE ASSEMBLY IS FOUR (4) CONTAINERS HIGH.
8. THE WIREBOUND CONTAINERS MUST BE POSITIONED WITH THE 13-1/2" DIMENSION ACROSS THE CAR WIDTH AS SHOWN IN THE "ISOMETRIC VIEW" ON PAGE 15.
9. IF A WIDER CAR IS USED FOR SHIPPING THE DEPICTED LOAD, THE WIDTH OF THE "SPACER ASSEMBLY E" MAY BE INCREASED BY LAMINATING 4" WIDE BY LOAD HEIGHT BY THICKNESS TO SUIT MATERIAL TO THE LOAD BEARING PIECES.
10. IF A NARROWER CAR IS USED FOR SHIPPING THE DEPICTED LOAD, THE WIDTH OF THE "SPACER ASSEMBLY E" MAY BE DECREASED BY USING 1" THICK MATERIAL IN LIEU OF 2" THICK MATERIAL FOR THE LOAD BEARING PIECES. IF AN 8'-6" WIDE CAR IS USED, ONLY SEVEN (7) WIREBOUND CONTAINERS CAN BE POSITIONED ACROSS THE CAR WIDTH. IF THE EXCESS SPACE ACROSS THE WIDTH OF THE CAR IS 1-1/2" OR LESS, NO SPACER ASSEMBLY IS REQUIRED.
11. IF THE CAR BEING LOADED HAS BOWED END WALLS WHICH ARE BOWED OUTWARD TWO INCHES (2") OR MORE EITHER FROM SIDE-TO-SIDE OR FROM FLOOR-TO-ROOF, AN END-OF-CAR BULKHEAD MUST BE INSTALLED TO PROVIDE A "SQUARED OFF" SURFACE FOR THE LOAD AT THE END OF THE CAR.
12. POSITION THE DIAGONAL BRACE, SHOWN AS PIECE MARKED ⑦, TIGHT AGAINST THE HOLD-DOWN CLEAT ON THE LCL GATE ASSEMBLY AND IN LINE WITH THE INSIDE EDGE OF THE FLOOR CLEAT, AS SHOWN ABOVE, TO FACILITATE POSITIONING OF THE DIAGONAL BRACE SUPPORT, SHOWN AS PIECE MARKED ⑧ ON PAGE 15.

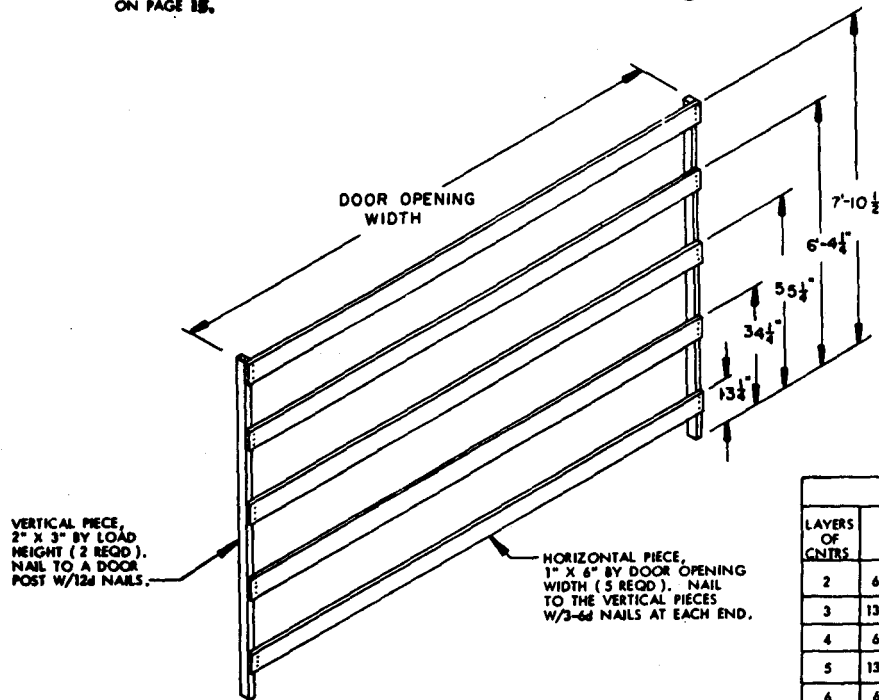

VERTICAL PIECE, 2" X 3" BY LOAD HEIGHT (2 REQD). NAIL TO A DOOR POST W/12d NAILS.

HORIZONTAL PIECE, 1" X 4" BY DOOR OPENING WIDTH (5 REQD). NAIL TO THE VERTICAL PIECES W/2-6d NAILS AT EACH END.

DOORWAY PROTECTION GATE I

FOR USE WITH UNUNITIZED WIREBOUND CONTAINERS. THE GATE SHOWN ABOVE IS FOR A NINE TIER LOAD. SEE "CHART C" ON THIS PAGE FOR LESS THAN NINE TIER LOADS. NOTE: IF THE DOOR POSTS ARE NOT NAILABLE, REFER TO THE "ALTERNATIVE DOORWAY PROTECTION" ON THIS PAGE.

CHART C					
LAYERS OF CNTRS	HEIGHT OF HORIZONTAL PIECES REQUIRED				
	2	6"	21"	*	*
3	13-1/4"	31-1/2"	*	*	*
4	6"	24"	42"	*	*
5	13-1/4"	34-1/4"	52-1/2"	*	*
6	6"	24"	45"	63"	*
7	13-1/4"	34-1/4"	52-1/2"	73-1/2"	*
8	6"	24"	45"	66"	84"
9	13-1/4"	34-1/4"	55-1/4"	76-1/4"	94-1/2"

* HORIZONTAL PIECE IS NOT REQUIRED.

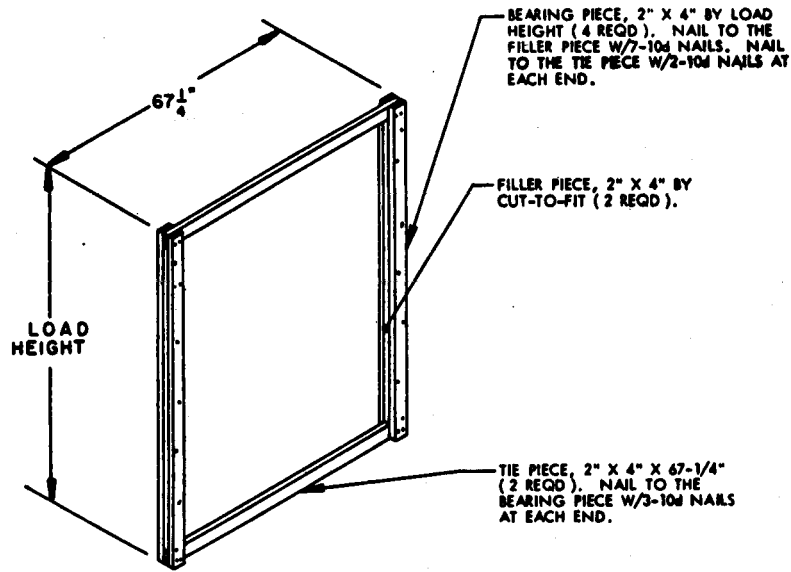

SPACER ASSEMBLY E

FOR USE WITH UNUNITIZED WIREBOUND CONTAINERS.

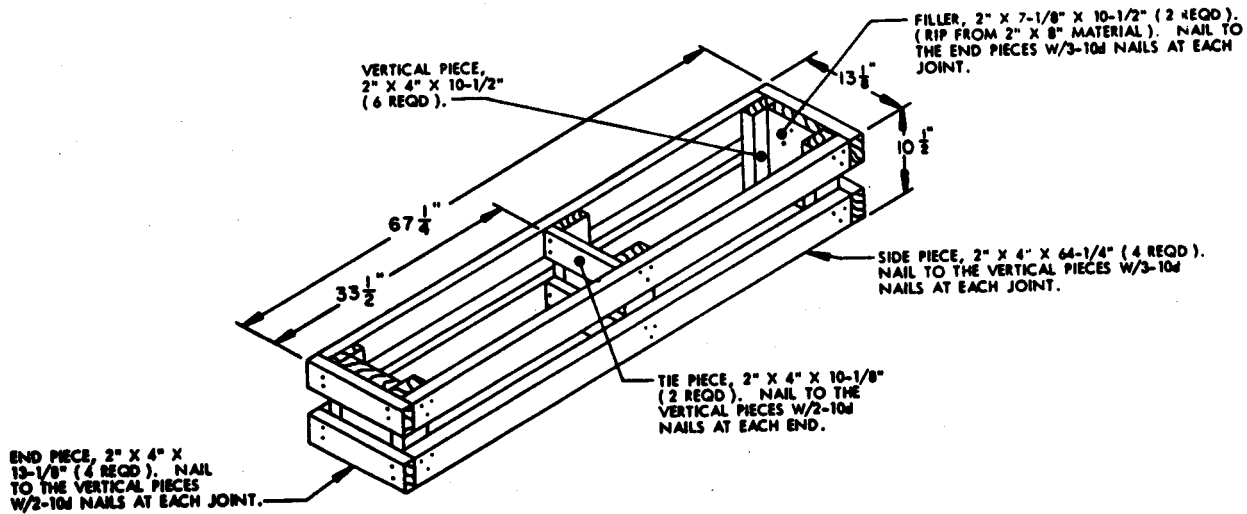

FILLER ASSEMBLY F

THE FILLER ASSEMBLY SHOWN ABOVE IS TO BE USED WITHIN LOADS TO TAKE THE PLACE OF AN OMITTED WIREBOUND CONTAINER. IT MUST BE USED IN THE TOP LAYER ONLY.

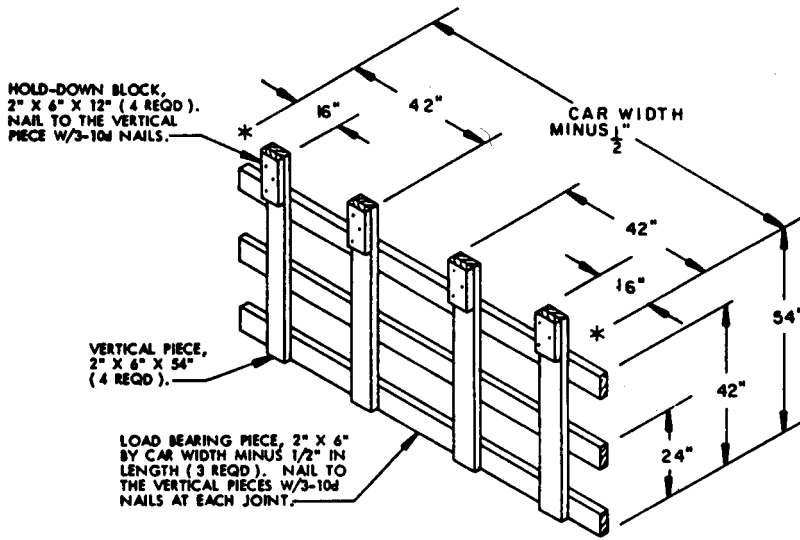

LCL GATE ASSEMBLY M

FOR USE WITH UNUNITIZED WIREBOUND CONTAINERS.

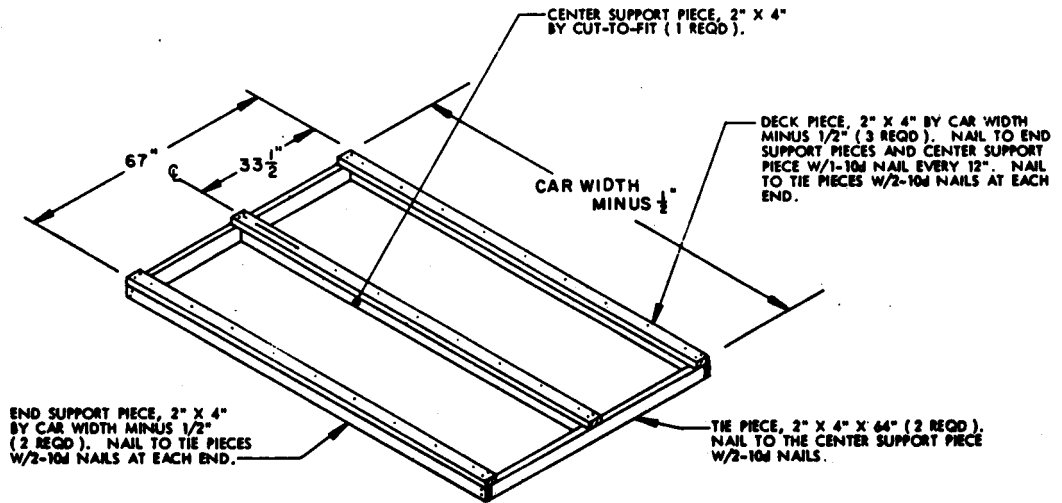

RISER ASSEMBLY G

FOR USE WITH UNUNITIZED WIREBOUND CONTAINERS.

APPENDIX

REFERENCES

1. Publication Indexes

Department of the Army pamphlets of the 310-series should be consulted frequently for the latest changes or revisions of references given in this appendix and for new publications relating to material covered in this manual.

2. Army Regulations (AR)

55-15	Land Transportation Within Areas Outside the Continental United States
55-29	Military Convoy Operations in CONUS
55-162	Permits for Oversize, Overweight, or Other Special Military Movements on Public Highways in the United States
55-228	Transportation by Water of Explosives and Hazardous Cargo
55-355	Military Traffic Management Regulation
70-47	Engineering for Transportability
95-27	Operational Procedures for Aircraft Carrying Hazardous Materials
360-5	Public Information
380-5	Department of the Army Information Security Program
385-40	Accident Reporting and Records
740-1	Storage and Supply Activity Operations
746-1	Packaging of Army Material for Shipment and Storage

3. Army Field Manuals (FM)

5-36	Route Reconnaissance and Classification
55-15	Transportation Reference Data
55-17	Terminal Operations Coordinator's Handbook
55-450-19	Army Helicopter External Load Operations

4. Army Supply Bulletins (SB)

700-20	Army Adopted/Other Items Selected for Authorization/List of Reportable Items.
--------	---

5. Army Technical Bulletins (TB)

55-46-1	Standard Characteristics (Dimensions, Weight, and Cube) for Transportability of Military Vehicles and Other Outsize, Overweight Equipment
---------	---

6. Army Technical Manuals (TM)

5-315	Fire Fighting and Rescue Operations in Theaters of Operations
5-725	Rigging
9-1300-206	Ammunition and Explosives Standards
38-250 (AFR 71-4)	Packaging and Materials Handling: Preparation of Hazardous Materials for Military Air Shipment
55-450-8	Air Transport of Supplies and Equipment: External Transport Procedures
55-450-11	Air Transport of Supplies and Equipment: Helicopter External Loads Rigged with Air Delivery Equipment
55-450-12	Air Transport of Supplies and Equipment: Helicopter External Loads for Sling, Nylon and Chain, Multiple Leg
55-450-15	Air Movement of Troops and Equipment (Nontactical)
55-450-18	Air Transport of Supplies and Equipment: Internal and External Loads, CH-47 Helicopter

TM 55-1425-429-14

55-1520-209-10 Operator's Manual:	Army Model CH-47A Helicopter
55-1520-210-10 Operator's Manual:	UH-1D/H and EH-1H Helicopters
55-1520-217-10-1 Operator's Manual:	Army Model CH-54A Helicopters
55-1520-217-10-2 Operator's Manual:	Army Model, CH-54B Helicopters
55-1520-219-10 Operator's Manual:	Army Model, UH-1B Helicopter
55-1520-220-10 Operator's Manual:	Army Model, UH-1C/M Helicopter
55-1520-227-10-1 Operator's Manual:	Army Model CH-47B Helicopter
55-1520-227-10-2 Operator's Manual:	Army Model CH-47C Helicopter
55-1520-237-10 Operator's Manual:	UH-60A Helicopter

7. Air Force Manuals (AFM)

TO 1-1B-40	Handbook of Weight and Balance Data
TO 1C-130A-9	Cargo Loading Instructions USAF Series C-130 Aircraft
TO 1C-141A-9	Cargo Loading Instructions USAF Series C-141 Aircraft
TO 1C-5A-9	Cargo Loading Instructions USAF Series C-5 Aircraft

NOTE

Air Force Technical Orders (T.O.) that have not been integrated into the Department of the Army publications system may be requisitioned through the Adjutant General Office in accordance with AR 310-70.

portation (Rail, Highway, and Water).
Available from:

Superintendent of Documents
US Government Printing Office
Washington, DC 20402

9. Department of Defense Directive

DOD 5100. 76-M Physical Security of Sensitive Conventional Arms, Ammunition, and Explosives

8. Department of Transportation

Code of Federal Regulations, Title 49 Trans-

By Order of the Secretary of the Army:

E. C. MEYER
General, United States Army
Chief of Staff

Official:

J. C. PENNINGTON
Major General, United States Army
The Adjutant General

DISTRIBUTION:

To be distributed in accordance with DA Form 12-32, Organizational Maintenance requirements for STINGER Weapon System.

* U.S. GOVERNMENT PRINTING OFFICE : 1990 - 275-340

RECOMMENDED CHANGES TO EQUIPMENT TECHNICAL PUBLICATIONS



THEN...JOT DOWN THE DOPE ABOUT IT ON THIS FORM. CAREFULLY TEAR IT OUT, FOLD IT AND DROP IT IN THE MAIL.

SOMETHING WRONG WITH PUBLICATION

FROM: (PRINT YOUR UNIT'S COMPLETE ADDRESS)

DATE SENT

PUBLICATION NUMBER

PUBLICATION DATE

PUBLICATION TITLE

BE EXACT PIN-POINT WHERE IT IS

PAGE NO.

PARA-GRAPH

FIGURE NO.

TABLE NO.

IN THIS SPACE, TELL WHAT IS WRONG AND WHAT SHOULD BE DONE ABOUT IT.

TEAR ALONG PERFORATED LINE

PRINTED NAME, GRADE OR TITLE AND TELEPHONE NUMBER

SIGN HERE

